

Hacking Techniques & Intrusion Detection

Fall 2012/2013

Dr. Ali Al-Shemery

aka: B!n@ry

Software Exploitation

Prepared by:

Dr. Ali Al-Shemery

Mr. Shadi Naif

Outline – Part 1

- Software Exploitation Intro.
- CPU Instructions & Registers
- Functions, High Level View
- Stacks and Stack Frames
- Memory Addressing
- Managing Stack Frames
- Functions, Low Level View
 - Understanding the Process
 - Call Types
 - Assembly Language
 - General Trace
 - Code Optimizations
 - Stack Reliability

Software Exploitation Intro.

- A program is made of a set of rules following a certain execution flow that tells the computer what to do.
- Exploiting the program (Goal):
 - Getting the computer to do what you want it to do, even if the program was designed to prevent that action [*The Art of Exploitation, 2nd Ed*].
- First documented attack 1972 (US Air Force Study).
- Even with the new mitigation techniques, software today is still exploited!

What is needed?

- To understand software exploitation, we need a well understanding of:
 - Computer Languages,
 - Operating Systems,
 - Architectures.

What will be covered?

- What we will cover is:
 - CPU Registers,
 - How Functions Work,
 - Memory Management for the IA32 Architecture,
 - A glance about languages: Assembly and C.
- Why do I need those?
 - Because most of the security holes come from memory corruption!

CPU Instructions & Registers

- The CPU contains many registers depending on its model & architecture.
- In this lecture, we are interested in three registers: EBP, ESP, and EIP which is the instruction pointer.
- (Instruction) is the lowest execution term for the CPU. (Statement) is a high level term that is compiled and then loaded as one or many instructions.
- Assembly language is the human friendly representation of the instructions machine code.

CPU Registers Overview

16 Bits	32 Bits	64 Bits	Description
AX	EAX	RAX	Accumulator
BX	EBX	RBX	Base Index
CX	ECX	RCX	Counter
DX	EDX	RDX	Data
BP	EBP	RBP	Base Pointer
SP	ESP	RSP	Stack Pointer
IP	EIP	RIP	Instruction Pointer
SI	ESI	RSI	Source Index Pointer
DI	EDI	RDI	Destination Index Pointer

- Some registers can be accessed using their lower and higher words. For example, AX register; lower word AL and higher word AH can be accessed separately.
- The above is not the complete list of CPU registers.

Functions, High Level View

```
void myfun2(char *x) {  
    printf("You entered: %s\n", x);  
}
```

```
void myfun1(char *str) {  
    char buffer[16];  
    strcpy(buffer, str);  
    myfun2(buffer);  
}
```

```
int main(int argc, char *argv[]) {  
    if (argc > 1)  
        myfun1(argv[1]);  
    else printf("No arguments!\n");  
}
```

A function consist of:

Name

Parameters (or arguments)

Body

Local variable definitions

Return value type

Functions, High Level View

```
void myfun2(char *x) {  
    printf("You entered: %s\n", x);  
}
```

A stack is the best structure to trace the program execution

```
void myfun1(char *str) {  
    char buffer[16];  
    strcpy(buffer, str);  
    myfun2(buffer);  
}
```

Current Statement

```
int main(int argc, char *argv[]) {  
    if (argc > 1)  
        myfun1(argv[1]);  
    else printf("No arguments!\n");  
}
```

Saved Return Positions



Functions, High Level View

```
void myfun2(char *x) {  
    printf("You entered: %s\n", x);  
}
```

A stack is the best structure to trace the program execution

```
void myfun1(char *str) {  
    char buffer[16];  
    strcpy(buffer, str);  
    myfun2(buffer);  
}
```

Current Statement

```
int main(int argc, char *argv[]) {  
    if (argc > 1)  
        myfun1(argv[1]);  
    else printf("No arguments!\n");  
}
```

Saved Return Positions

Functions, High Level View

```
void myfun2(char *x) {  
    printf("You entered: %s\n", x);  
}
```

A stack is the best structure to trace the program execution

```
void myfun1(char *str) {  
    char buffer[16];  
    strcpy(buffer, str);  
    myfun2(buffer);  
}
```

Current Statement

```
int main(int argc, char *argv[]) {  
    if (argc > 1)  
        myfun1(argv[1]);  
    else printf("No arguments!\n");  
}
```

Saved Return Positions

Functions, High Level View

```
void myfun2(char *x) {  
    printf("You entered: %s\n", x);  
}
```

```
void myfun1(char *str) {  
    char buffer[16];  
    strcpy(buffer, str);  
    myfun2(buffer);  
}
```

```
int main(int argc, char *argv[]) {  
    if (argc > 1)  
        myfun1(argv[1]);  
    else printf("No arguments!\n");  
}
```

A stack is the best structure to trace the program execution

Current Statement

Saved Return Positions

PUSH position into the Stack

myfun1(argv[1]);

Functions, High Level View

```
void myfun2(char *x) {  
    printf("You entered: %s\n", x);  
}
```

```
void myfun1(char *str) {  
    char buffer[16];  
    strcpy(buffer, str);  
    myfun2(buffer);  
}
```

```
int main(int argc, char *argv[]) {  
    if (argc > 1)  
        myfun1(argv[1]);  
    else printf("No arguments!\n");  
}
```

A stack is the best structure to trace the program execution

Current Statement

Saved Return Positions

myfun1(argv[1]);

Functions, High Level View

```
void myfun2(char *x) {  
    printf("You entered: %s\n", x);  
}
```

```
void myfun1(char *str) {  
    char buffer[16];  
    strcpy(buffer, str);  
    myfun2(buffer);  
}
```

```
int main(int argc, char *argv[]) {  
    if (argc > 1)  
        myfun1(argv[1]);  
    else printf("No arguments!\n");  
}
```

A stack is the best structure to trace the program execution

Current Statement

Saved Return Positions

myfun1(argv[1]);

Functions, High Level View

```
void myfun2(char *x) {  
    printf("You entered: %s\n", x);  
}
```

A stack is the best structure to trace the program execution

```
void myfun1(char *str) {  
    char buffer[16];  
    strcpy(buffer, str);  
    myfun2(buffer);  
}
```

Current Statement

```
int main(int argc, char *argv[]) {  
    if (argc > 1)  
        myfun1(argv[1]);  
    else printf("No arguments!\n");  
}
```

Saved Return Positions

myfun1(argv[1]);

Functions, High Level View

```
void myfun2(char *x) {  
    printf("You entered: %s\n", x);  
}
```

A stack is the best structure to trace the program execution

```
void myfun1(char *str) {  
    char buffer[16];  
    strcpy(buffer, str);  
    myfun2(buffer);  
}
```

Current Statement

```
int main(int argc, char *argv[]) {  
    if (argc > 1)  
        myfun1(argv[1]);  
    else printf("No arguments!\n");  
}
```

Saved Return Positions

myfun1(argv[1]);

Functions, High Level View

```
void myfun2(char *x) {  
    printf("You entered: %s\n", x);  
}
```

```
void myfun1(char *str) {  
    char buffer[16];  
    strcpy(buffer, str);  
    myfun2(buffer);  
}
```

```
int main(int argc, char *argv[]) {  
    if (argc > 1)  
        myfun1(argv[1]);  
    else printf("No arguments!\n");  
}
```

A stack is the best structure to trace the program execution

Current Statement

Saved Return Positions

PUSH position into the Stack

myfun2(buffer);

myfun1(argv[1]);

Functions, High Level View

```
void myfun2(char *x) {  
    printf("You entered: %s\n", x);  
}
```

```
void myfun1(char *str) {  
    char buffer[16];  
    strcpy(buffer, str);  
    myfun2(buffer);  
}
```

```
int main(int argc, char *argv[]) {  
    if (argc > 1)  
        myfun1(argv[1]);  
    else printf("No arguments!\n");  
}
```

A stack is the best structure to trace the program execution

Current Statement

Saved Return Positions

myfun2(buffer);

myfun1(argv[1]);

Functions, High Level View

```
void myfun2(char *x) {  
    printf("You entered: %s\n", x);  
}
```

```
void myfun1(char *str) {  
    char buffer[16];  
    strcpy(buffer, str);  
    myfun2(buffer);  
}
```

```
int main(int argc, char *argv[]) {  
    if (argc > 1)  
        myfun1(argv[1]);  
    else printf("No arguments!\n");  
}
```

A stack is the best structure to trace the program execution

Current Statement

Saved Return Positions

myfun2(buffer);

myfun1(argv[1]);

Functions, High Level View

```
void myfun2(char *x) {  
    printf("You entered: %s\n", x);  
}
```

```
}
```

```
void myfun1(char *str) {  
    char buffer[16];  
    strcpy(buffer, str);  
    myfun2(buffer);  
}
```

```
int main(int argc, char *argv[]) {  
    if (argc > 1)  
        myfun1(argv[1]);  
    else printf("No arguments!\n");  
}
```

A stack is the best structure to trace the program execution

Current Statement

Saved Return Positions

myfun2(buffer);

myfun1(argv[1]);

Functions, High Level View

```
void myfun2(char *x) {  
    printf("You entered: %s\n", x);  
}
```

```
void myfun1(char *str) {  
    char buffer[16];  
    strcpy(buffer, str);  
    myfun2(buffer);  
}
```

```
int main(int argc, char *argv[]) {  
    if (argc > 1)  
        myfun1(argv[1]);  
    else printf("No arguments!\n");  
}
```

A stack is the best structure to trace the program execution

Current Statement

Saved Return Positions

POP Position out of the Stack

myfun2(buffer);

myfun1(argv[1]);

Functions, High Level View

```
void myfun2(char *x) {  
    printf("You entered: %s\n", x);  
}
```

A stack is the best structure to trace the program execution

```
void myfun1(char *str) {  
    char buffer[16];  
    strcpy(buffer, str);  
    myfun2(buffer);
```

Current Statement

```
}
```

Saved Return Positions

```
int main(int argc, char *argv[]) {  
    if (argc > 1)  
        myfun1(argv[1]);  
    else printf("No arguments!\n");  
}
```

myfun1(argv[1]);

Functions, High Level View

```
void myfun2(char *x) {  
    printf("You entered: %s\n", x);  
}
```

```
void myfun1(char *str) {  
    char buffer[16];  
    strcpy(buffer, str);  
    myfun2(buffer);
```

```
}
```

```
int main(int argc, char *argv[]) {  
    if (argc > 1)  
        myfun1(argv[1]);  
    else printf("No arguments!\n");  
}
```

A stack is the best structure to trace the program execution

Current Statement

Saved Return Positions

POP Position out of the Stack

myfun1(argv[1]);

Functions, High Level View

```
void myfun2(char *x) {  
    printf("You entered: %s\n", x);  
}
```

A stack is the best structure to trace the program execution

```
void myfun1(char *str) {  
    char buffer[16];  
    strcpy(buffer, str);  
    myfun2(buffer);  
}
```

Current Statement

```
int main(int argc, char *argv[]) {  
    if (argc > 1)  
        myfun1(argv[1]);  
    else printf("No arguments!\n");  
}
```

Saved Return Positions

Functions, High Level View

```
void myfun2(char *x) {  
    printf("You entered: %s\n", x);  
}
```

A stack is the best structure to trace the program execution

```
void myfun1(char *str) {  
    char buffer[16];  
    strcpy(buffer, str);  
    myfun2(buffer);  
}
```

Current Statement

```
int main(int argc, char *argv[]) {  
    if (argc > 1)  
        myfun1(argv[1]);  
    else printf("No arguments!\n");  
}
```

Saved Return Positions

}

Functions, High Level View

```
void myfun2(char *x) {  
    printf("You entered: %s\n", x);  
}
```

A stack is the best structure to trace the program execution

```
void myfun1(char *str) {  
    char buffer[16];  
    strcpy(buffer, str);  
    myfun2(buffer);  
}
```

End of Execution

```
int main(int argc, char *argv[]) {  
    if (argc > 1)  
        myfun1(argv[1]);  
    else printf("No arguments!\n");  
}
```

Saved Return Positions



Stack & Stack Frames

- There is no “physical” stack inside the CPU. Instead; the CPU uses the main memory to represent a “logical” structure of a stack.
- The operating system reserves a contiguous raw memory space for the stack. This stack is logically divided into many Stack Frames.
- The stack and all stack frames are represented in the memory upside-down.
- A stack frame is represented by two pointers:
 - Base pointer (saved in EBP register): the memory address that is equal to (EBP-1) is the first memory location of the stack frame.
 - Stack pointer (saved in ESP register): the memory address that is equal to (ESP) is the top memory location of the stack frame.
- When Pushing or Popping values, ESP register value is changed (the stack pointer moves)
- Base Pointer (value of EBP) never change unless the current Stack Frame is changed.
- The stack frame is empty when EBP value = ESP value.

Memory Addressing

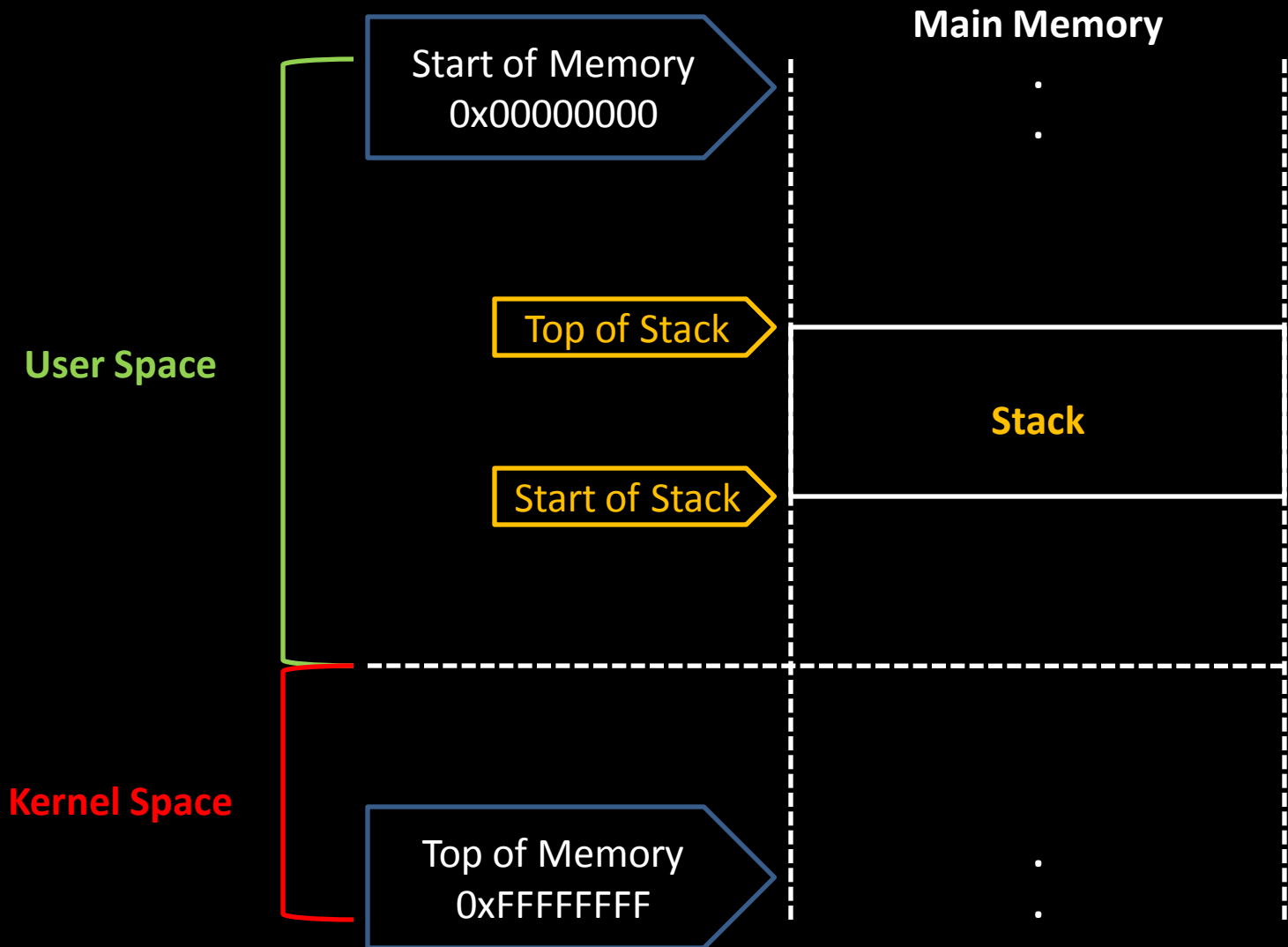

Stack & Stack Frames inside the Main Memory

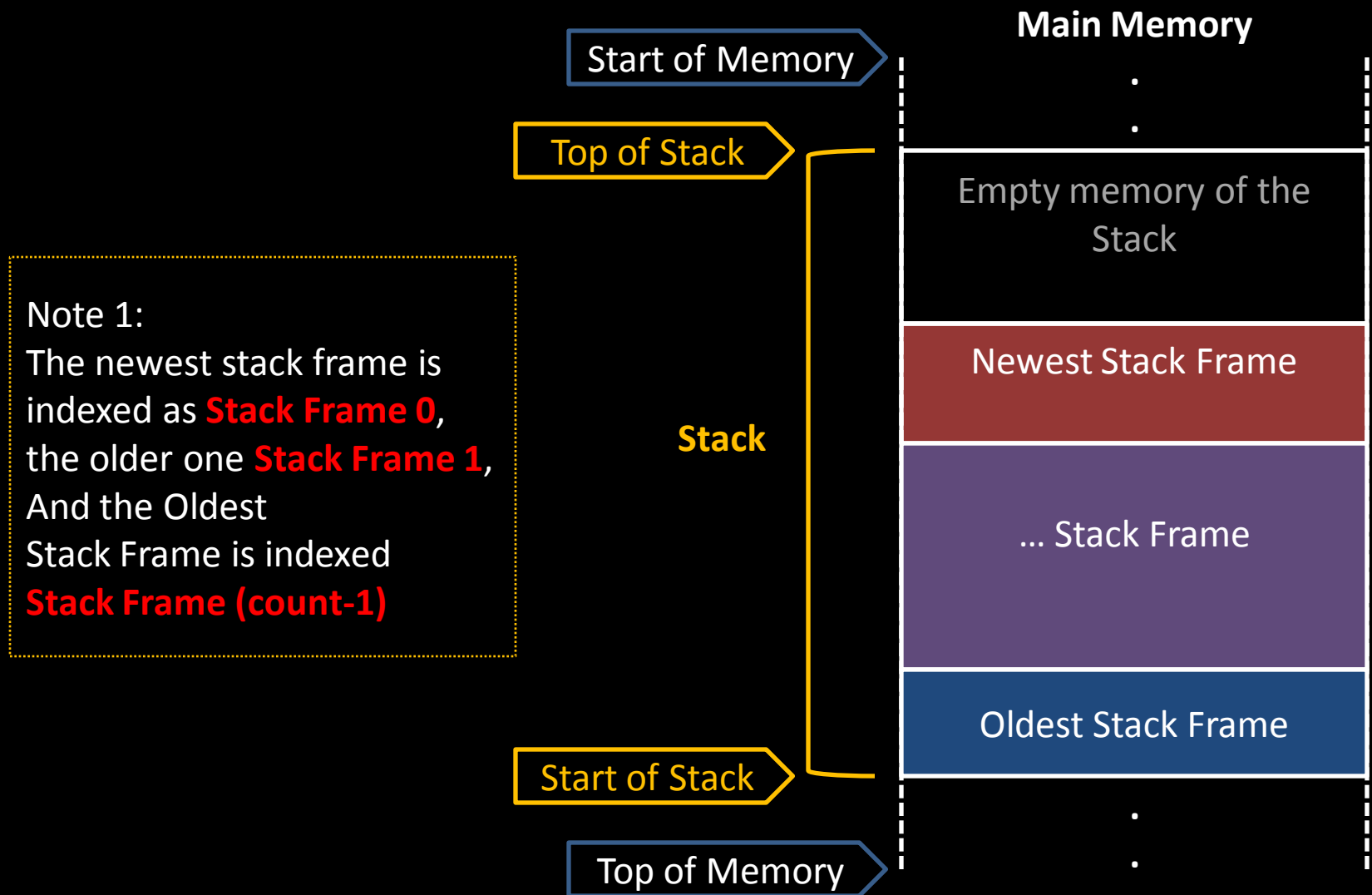

Managing Stack Frames

The Current Stack Frame is always the Newest Stack Frame

ESP points to the top of the current Stack Frame. And it points to the top of the **Stack** as well.

Whenever a function is called, a new Stack Frame is created. Local variables are also allocated in the bottom of the created Stack Frame.

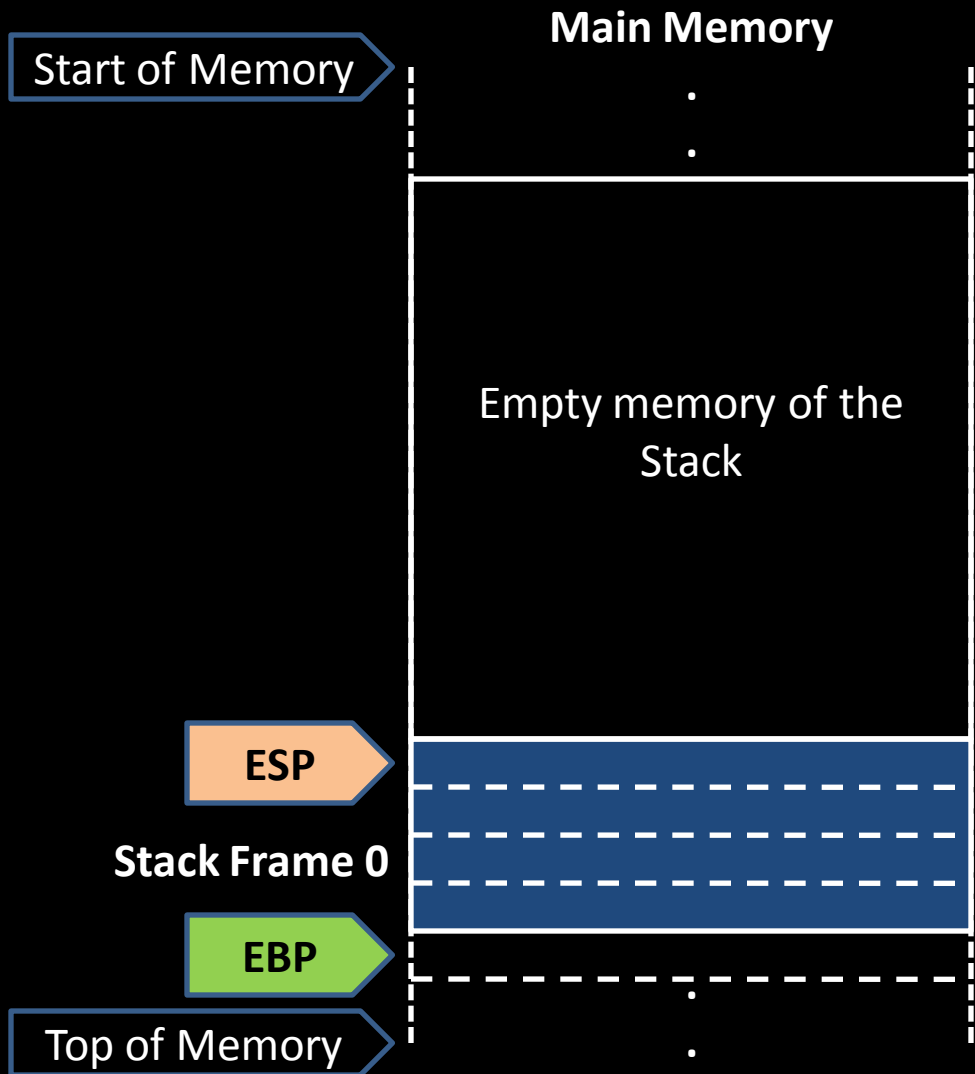

Managing Stack Frames

The Current Stack Frame is always the Newest Stack Frame

To create a new Stack Frame, simply change EBP value to be equal to ESP.

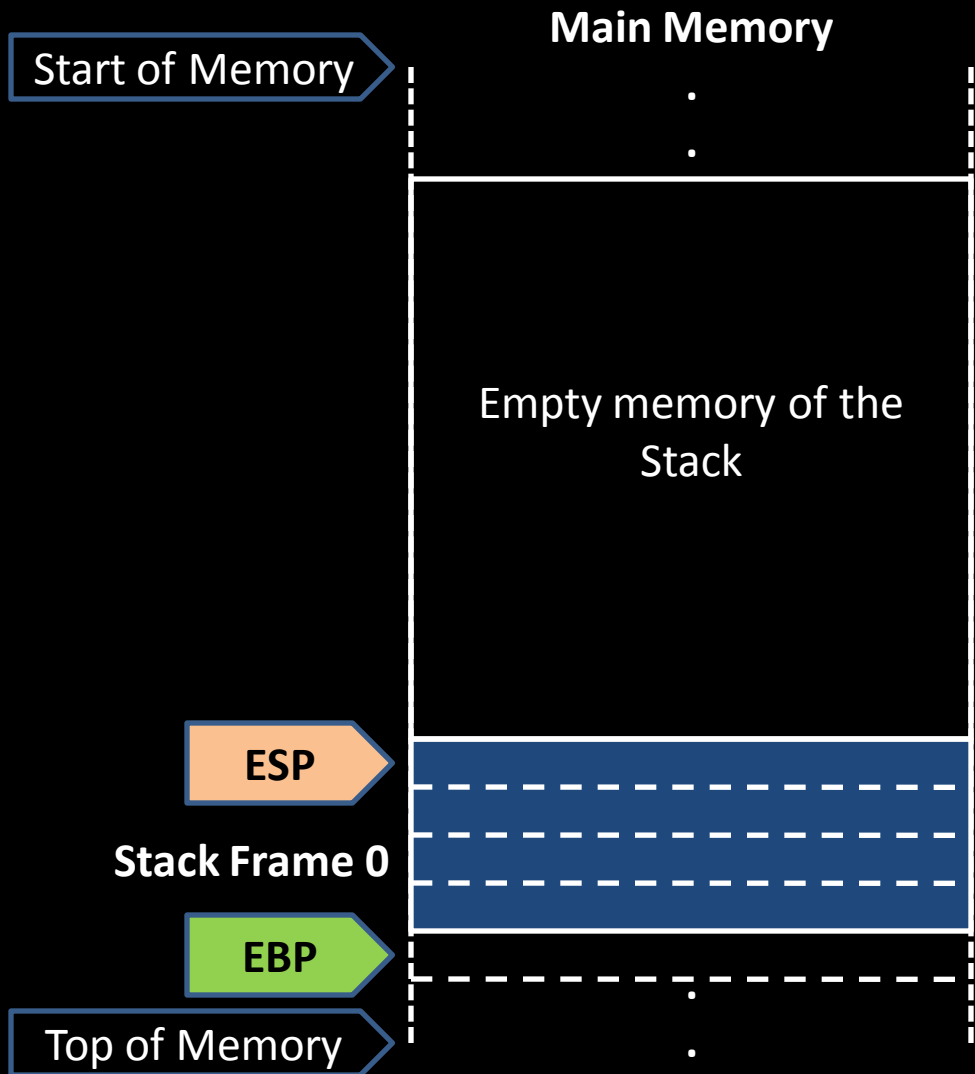

Managing Stack Frames

The Current Stack Frame is always the Newest Stack Frame

Now $EBP = ESP$, this means that the Newest Stack Frame is empty. The previous stack frame now is indexed as Stack Frame 1

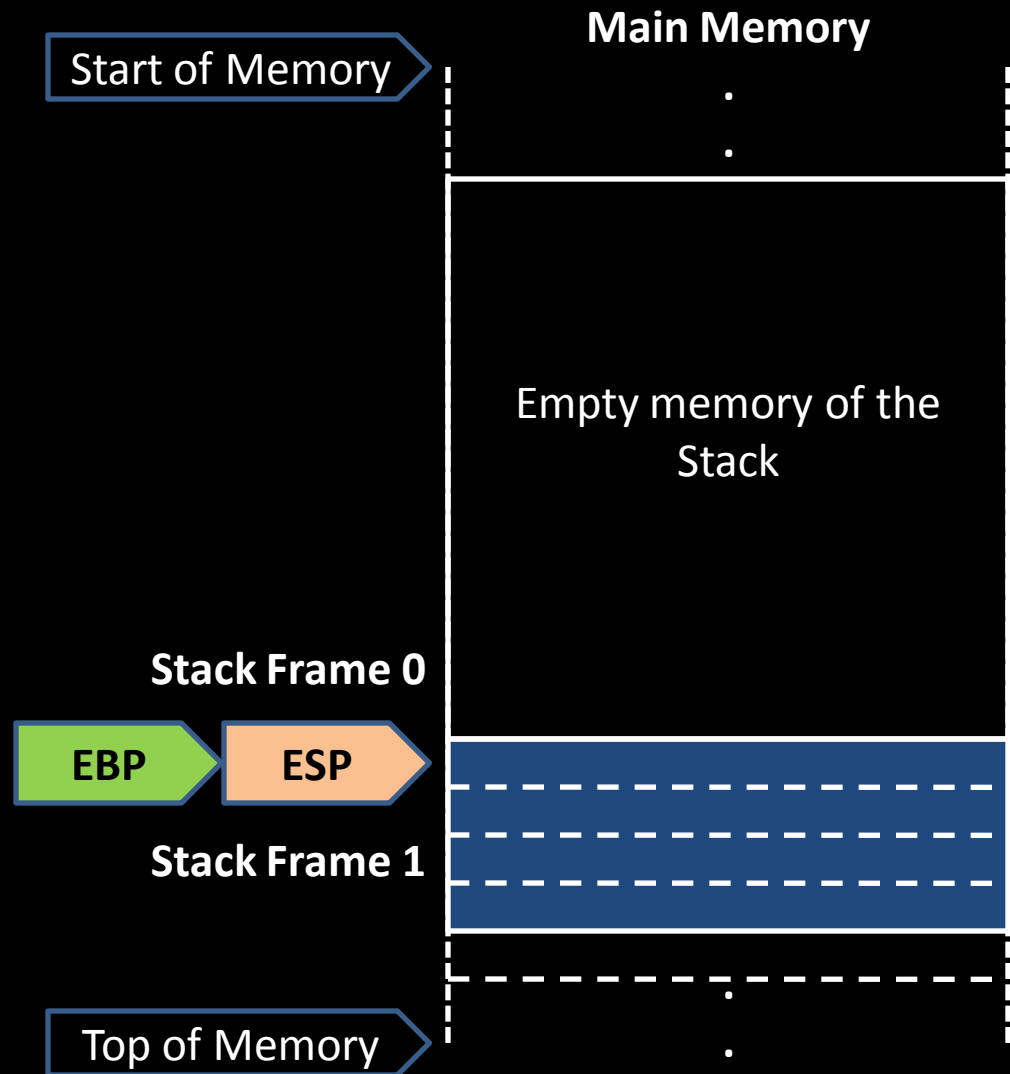

Managing Stack Frames

The Current Stack Frame is always the Newest Stack Frame

Now $EBP = ESP$, this means that the Newest Stack Frame is empty. The previous stack frame now is indexed as Stack Frame 1

Let's try again. This time we should save EBP value before changing it.

Start of Memory

Main Memory

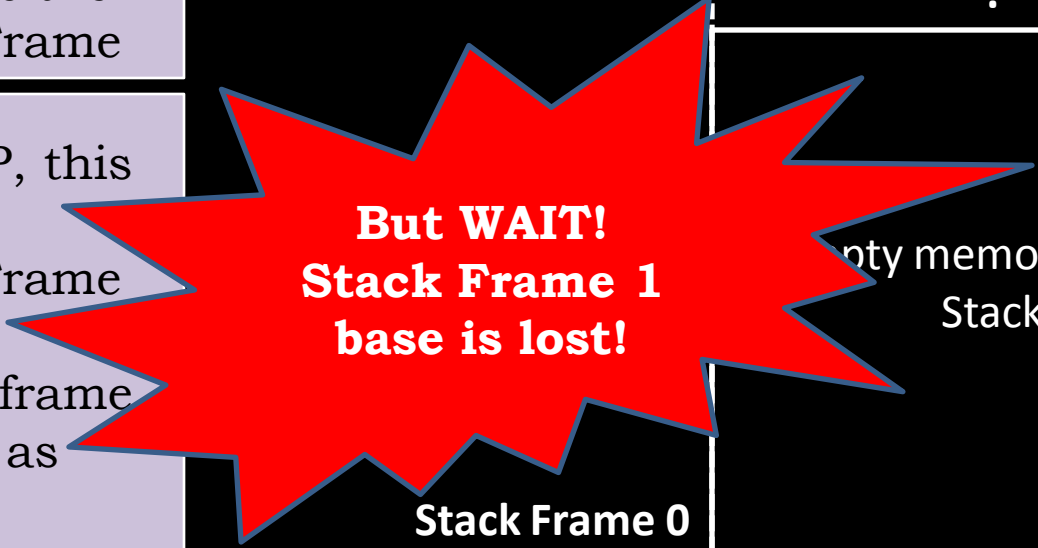

·
·
Empty memory of the Stack

Stack Frame 0



Stack Frame 1



Top of Memory

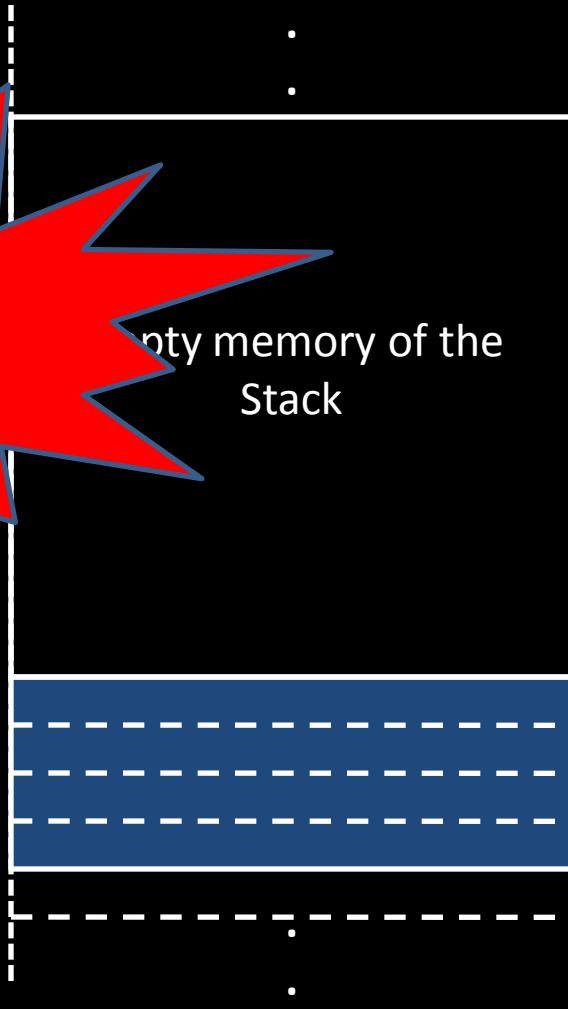

Managing Stack Frames

The Current Stack Frame is always the Newest Stack Frame

First, PUSH value of EBP to save it.

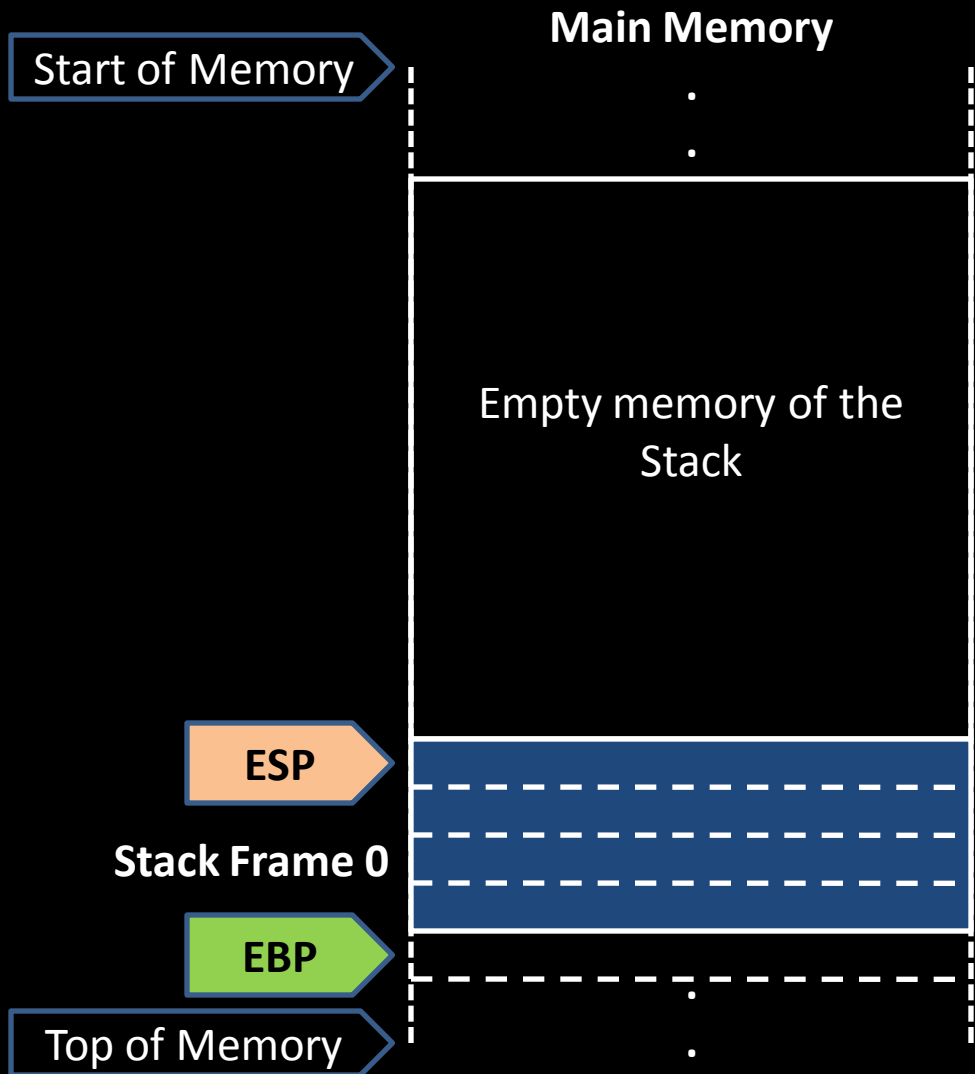

Managing Stack Frames

The Current Stack Frame is always the Newest Stack Frame

First, PUSH value of EBP to save it.

Now change the value of EBP.

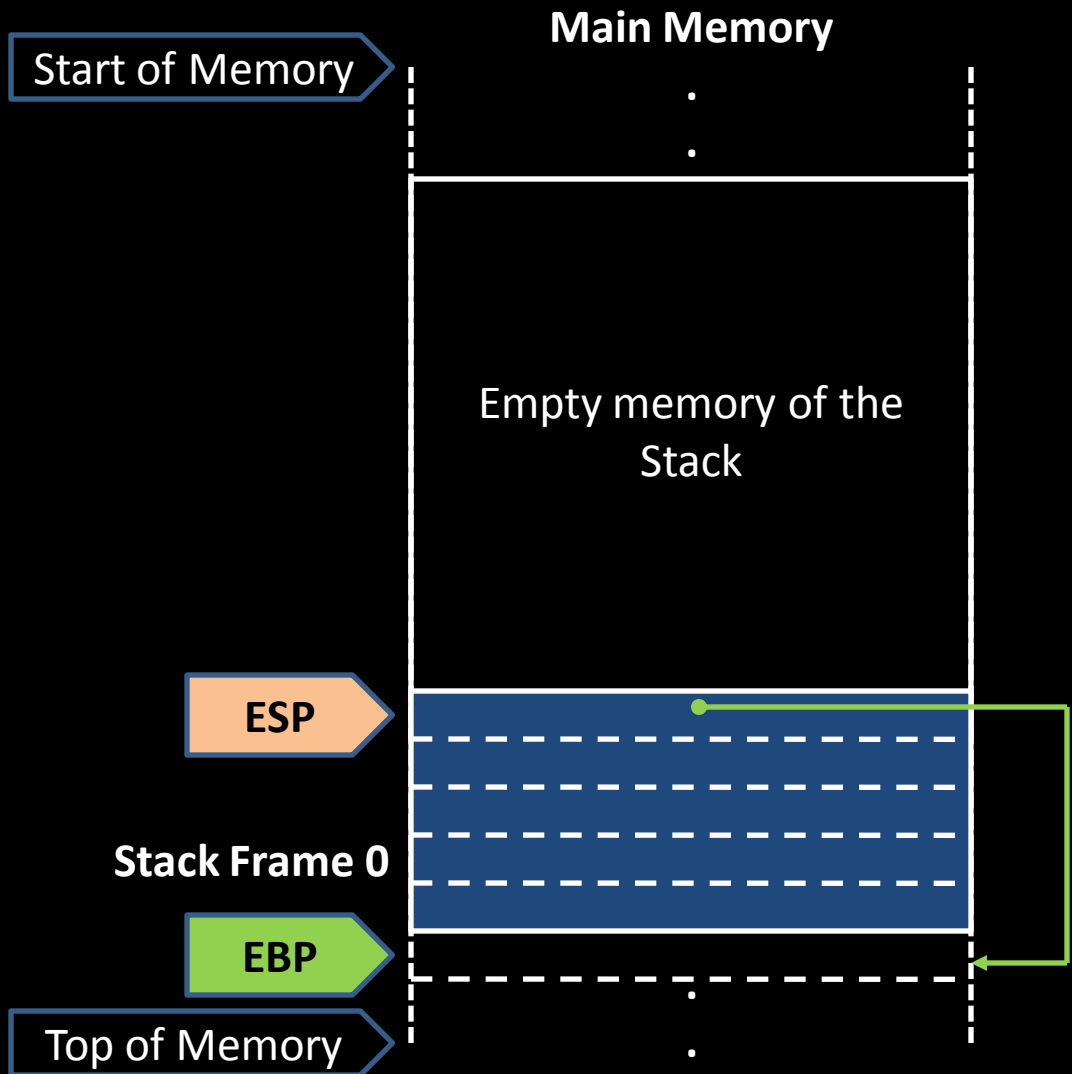

Managing Stack Frames

The Current Stack Frame is always the Newest Stack Frame

First, PUSH value of EBP to save it.

Now change the value of EBP.

PROLOGUE is:
Creating new Stack Frame then allocating space for local variables.

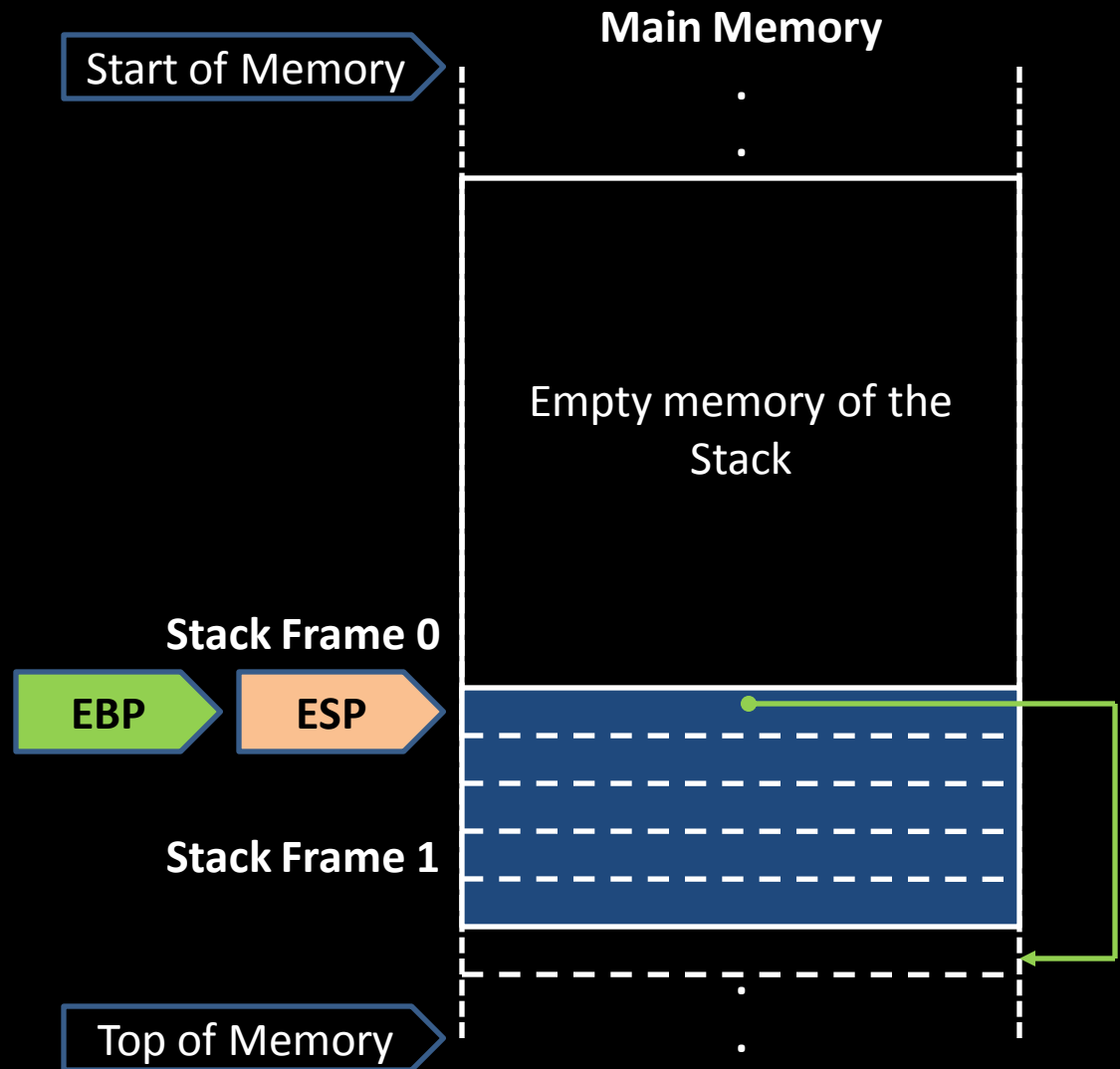

Managing Stack Frames

The Current Stack Frame is always the Newest Stack Frame

PUSH and POP operations affect ESP value only.

We don't need to save ESP value for the previous stack frame, because it is equal to the current EBP value

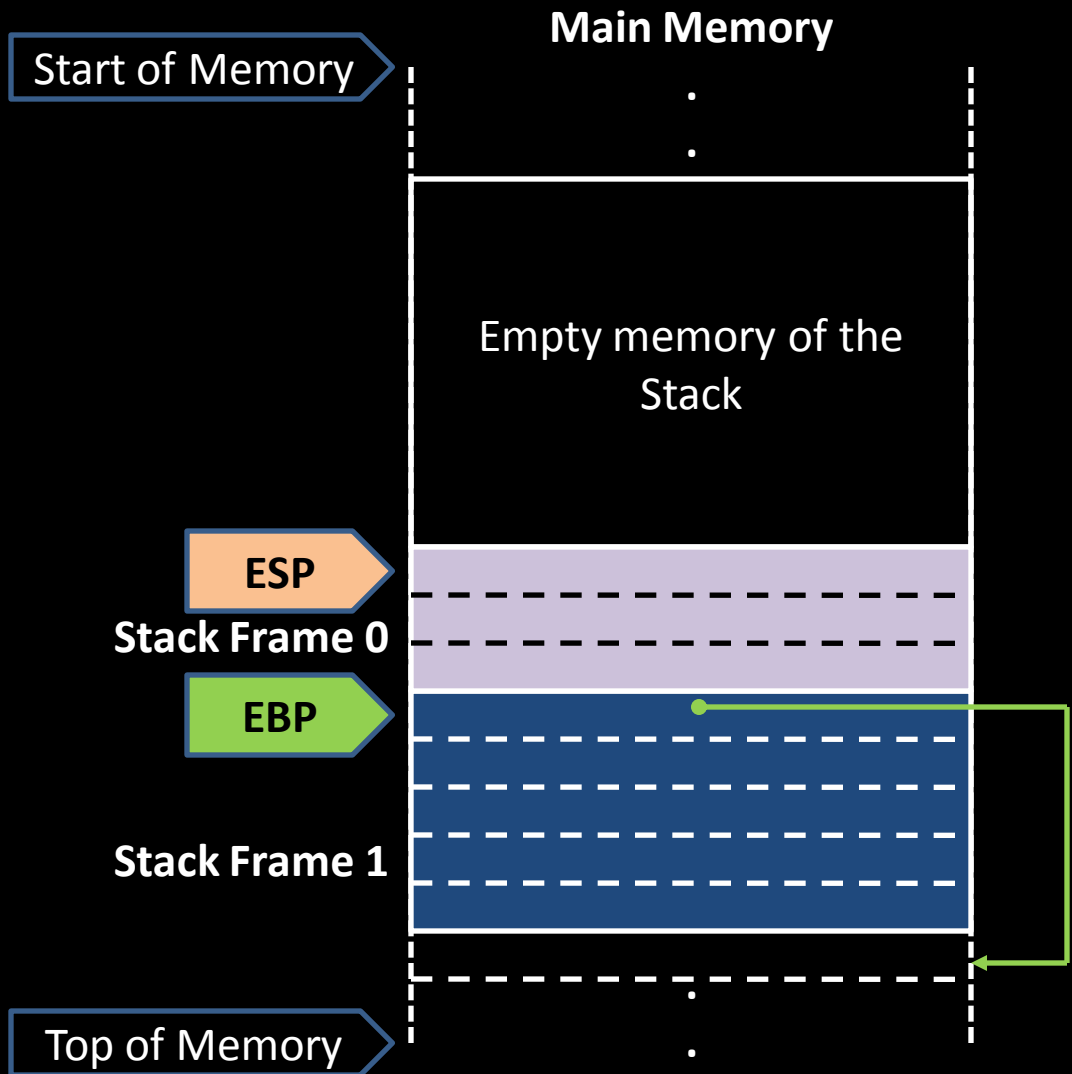

Managing Stack Frames

The Current Stack Frame is always the Newest Stack Frame

To empty out the current Stack Frame, ESP value should be set to the same value of EBP

Start of Memory

Main Memory

ESP
Stack Frame 0

EBP
Stack Frame 1

Stack Frame 1

Top of Memory

Empty memory of the Stack

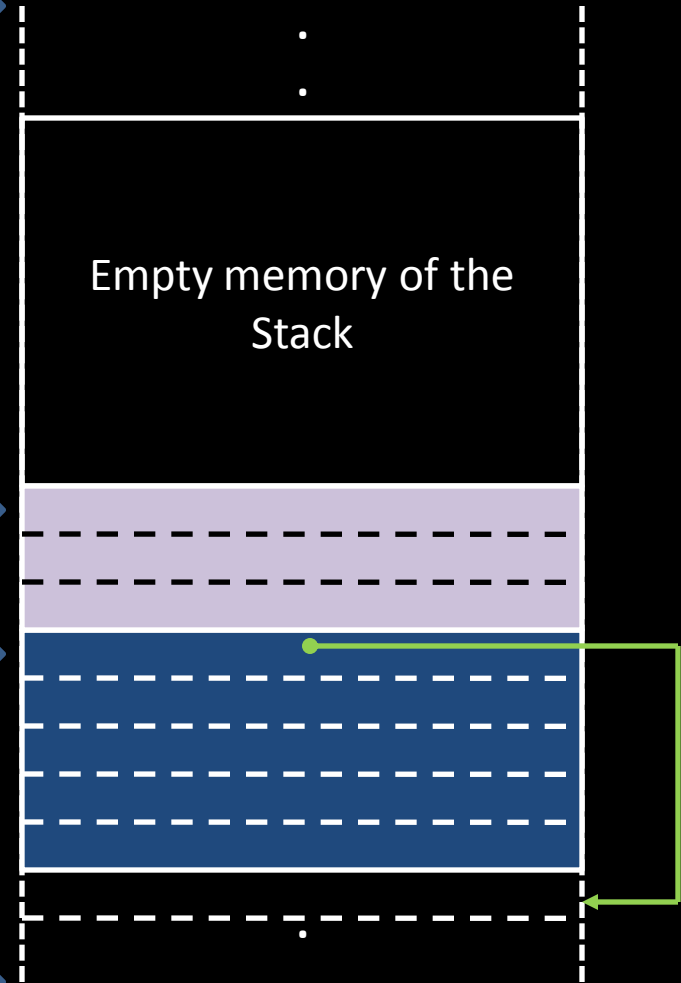

Managing Stack Frames

The Current Stack Frame is always the Newest Stack Frame

To empty out the current Stack Frame, ESP value should be set to the same value of EBP

To delete the current Stack Frame and return back to the previous one, we should POP out the top value from the **Stack** into EBP.

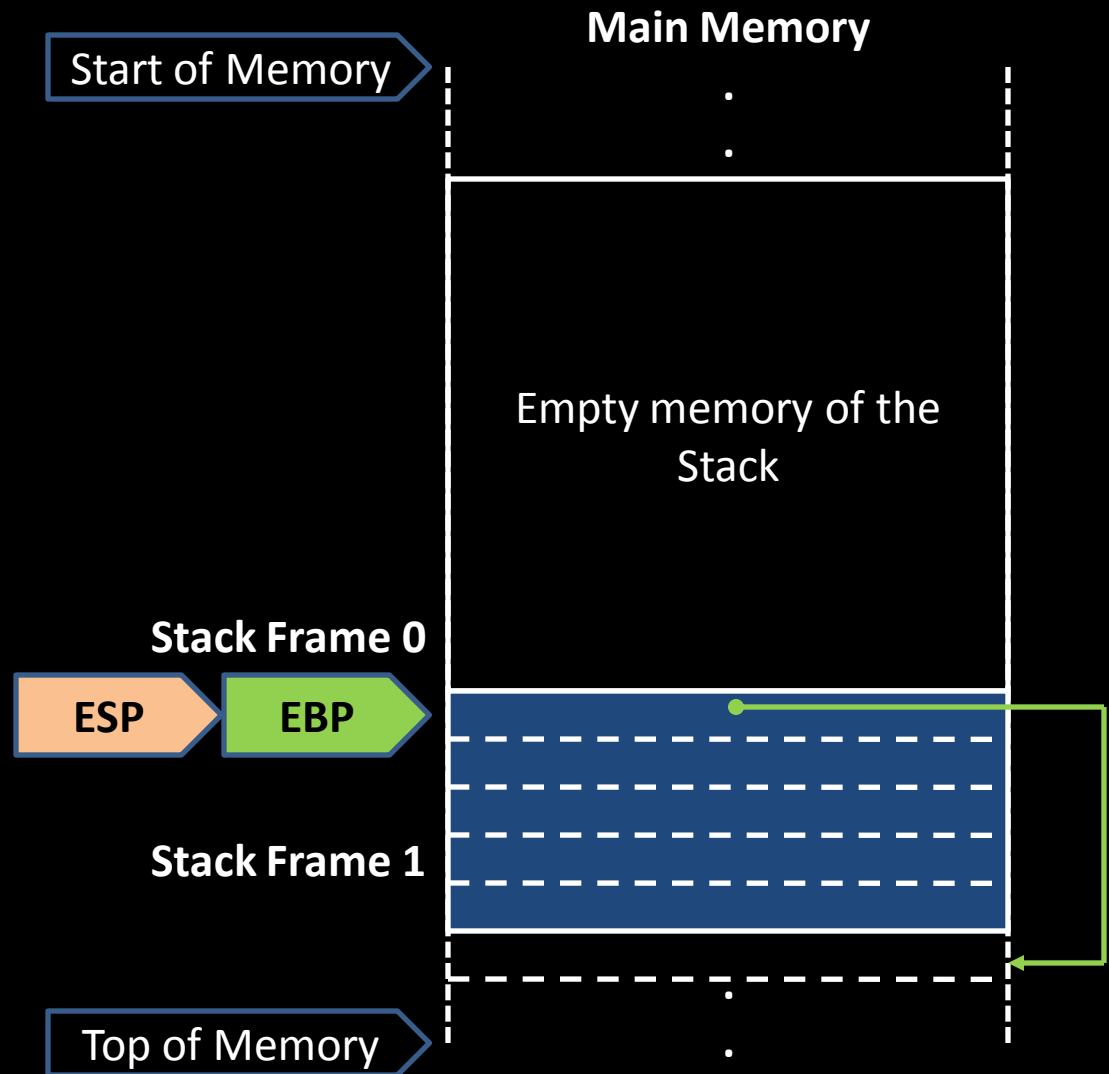

Managing Stack Frames

The Current Stack Frame is always the Newest Stack Frame

To empty out the current Stack Frame, ESP value should be set to the same value of EBP

To delete the current Stack Frame and return back to the previous one, we should POP out the top value from the **Stack** into EBP.

Start of Memory

EPILOGUE is:
Emptying the current stack frame and deleting it, then returning to the calling function

ESP

Stack Frame 0

EBP

Top of Memory

Main Memory

Empty memory of the Stack

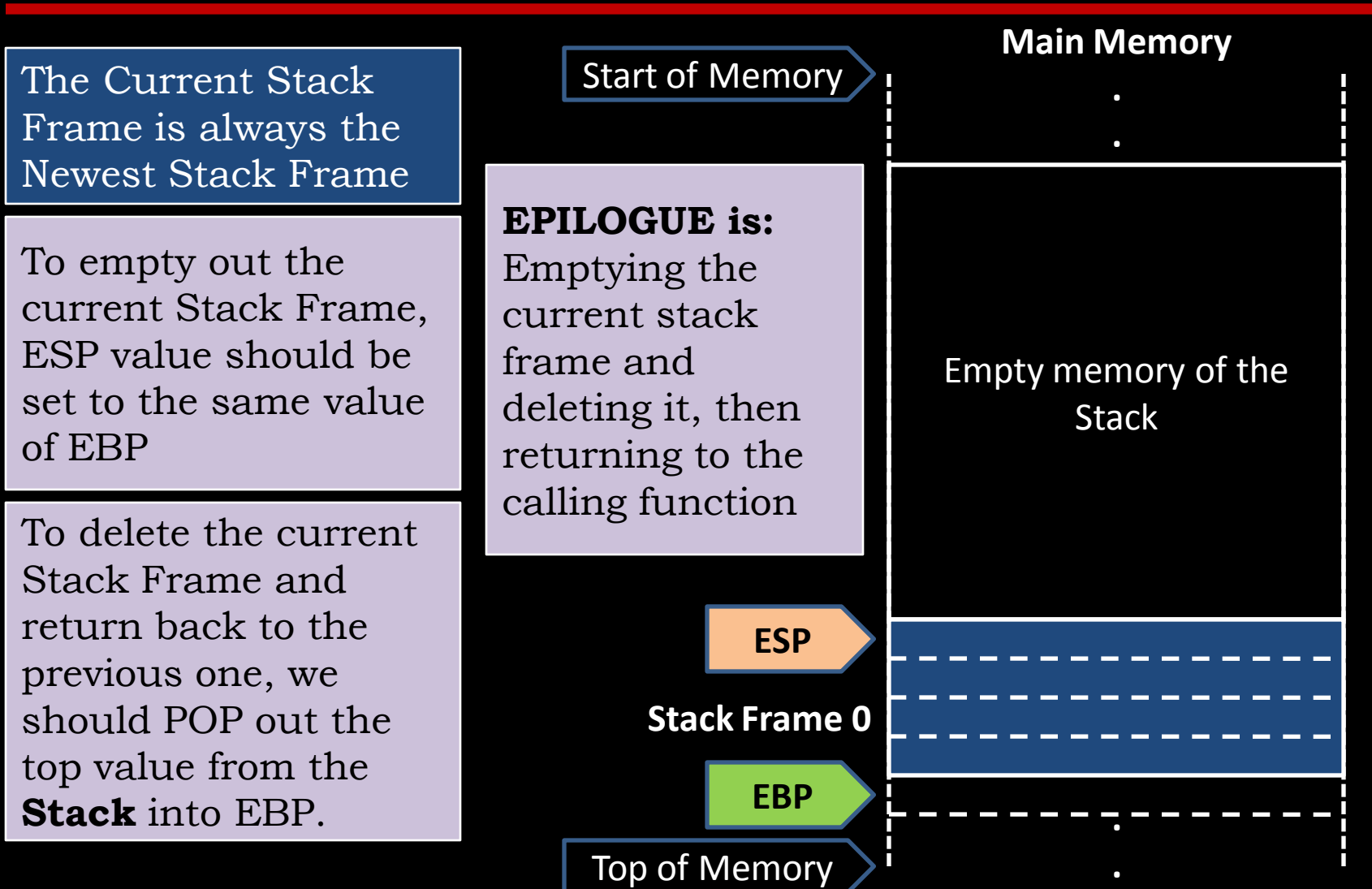

Functions, Low Level View

- Understanding the Process -

A simple function call in a high level language is not a simple operation as it seems.

```
add(x, y);
```

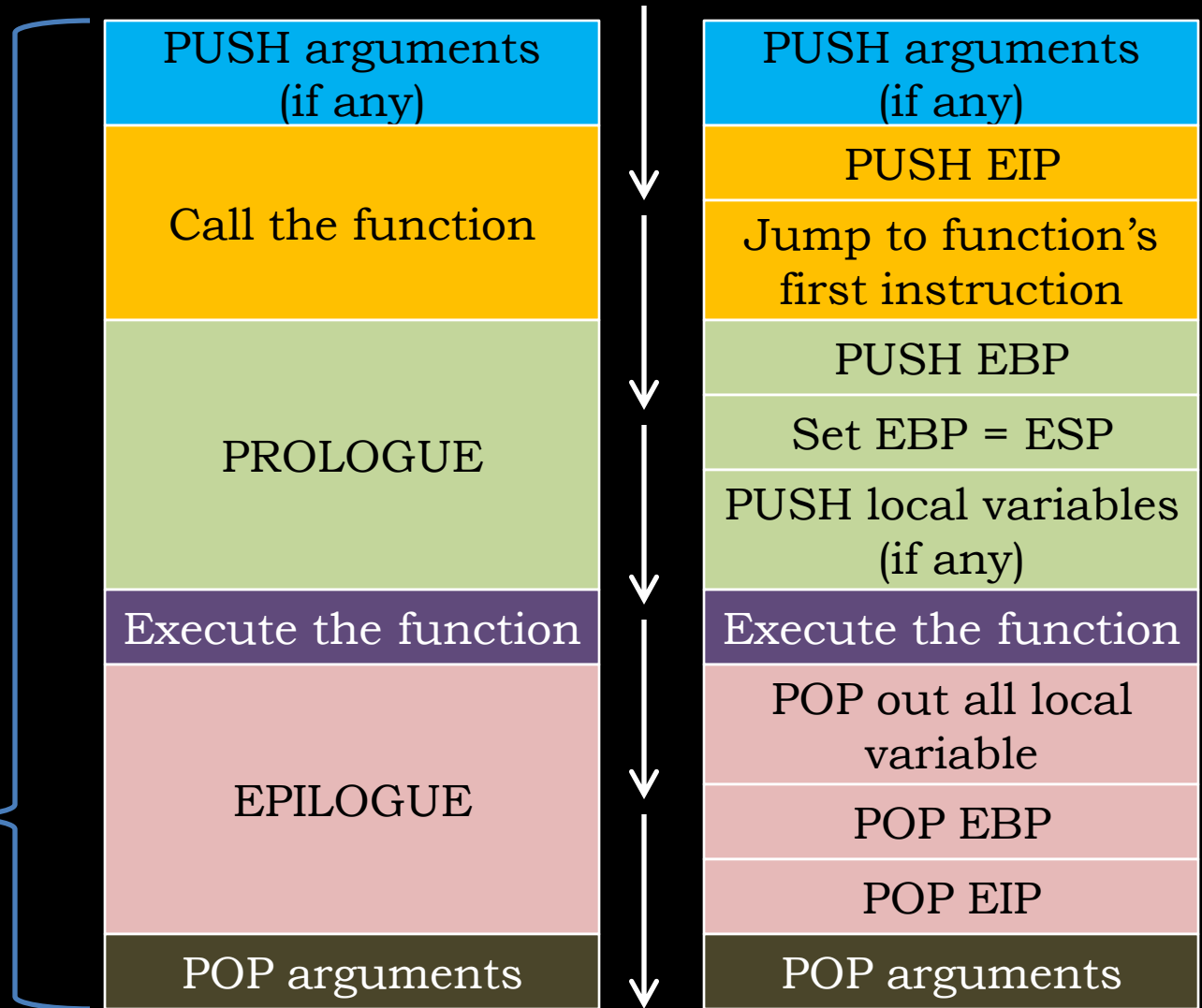

Functions, Low Level View

- Understanding the Process -

Each PUSH operation must be reversed by a POP operation somewhere in the execution

Performing (PUSH arguments) is done by the caller function. Arguments are pushed in a reverse order.

Performing (POP arguments) can be done by the caller or the callee function. This is specified by the (call type) of the callee function

Return value of the callee is saved inside EAX register while executing the function's body

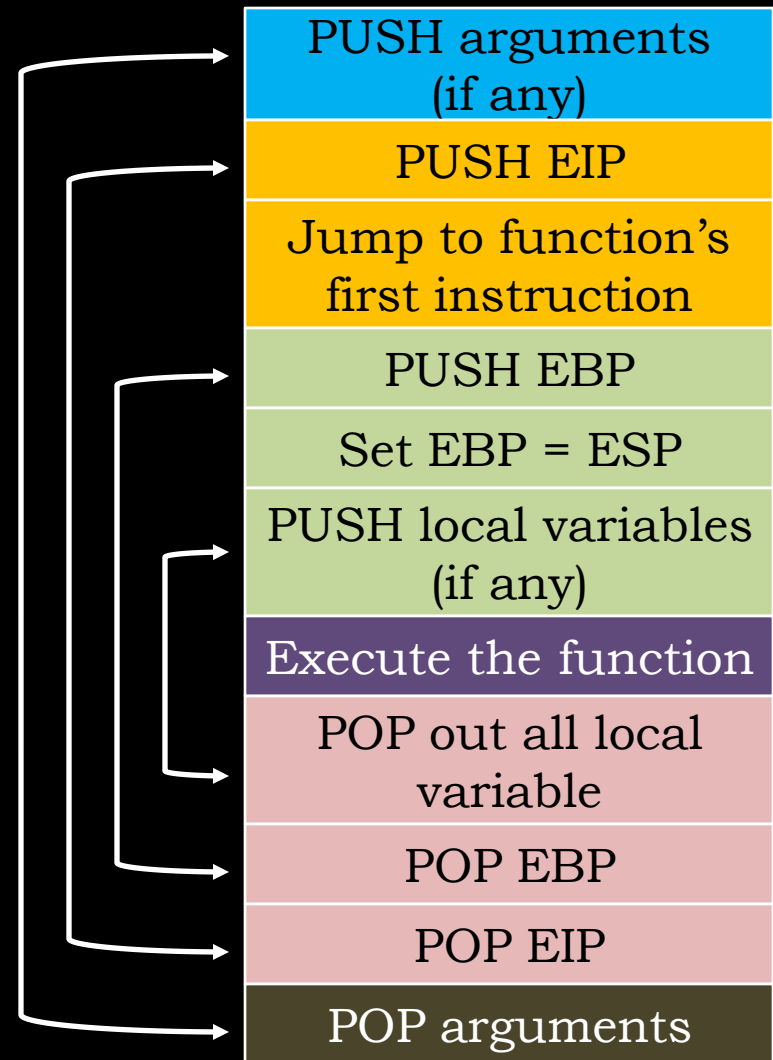

Functions, Low Level View

- Call Types -

- Programming languages provide a mechanism to specify the call type of the function.
- (**Call Type**) is not (**Return Value Type**).
- The caller needs to know the call type of the callee to specify how arguments should be passed and how Stack Frames should be cleaned.
- There are many call types; two of them are commonly used in most programming languages:
 - **cdecl**: the default call type for C functions. The caller is responsible of cleaning the stack frame.
 - **stdcall**: the default call type for Win32 APIs. The callee is responsible of cleaning the stack frame.
- Some call types use deferent steps to process the function call. For example, **fastcall** send arguments within Registers not by the stack frame. (Why?)

Functions, Low Level View

- Assembly Language -

Each of these steps are processed by one or many instructions.

As like as other programming languages; assembly provides many ways to perform the same operation. Therefore, the disassembled code can vary from one compiler to another.

Now we are going to introduce the default way for performing each of these steps using assembly language.

PUSH arguments
(if any)

PUSH EIP

Jump to function's
first instruction

PUSH EBP

Set EBP = ESP

PUSH local variables
(if any)

Execute the function

POP out all local
variable

POP EBP

POP EIP

POP arguments

Functions, Low Level View

- Assembly Language -

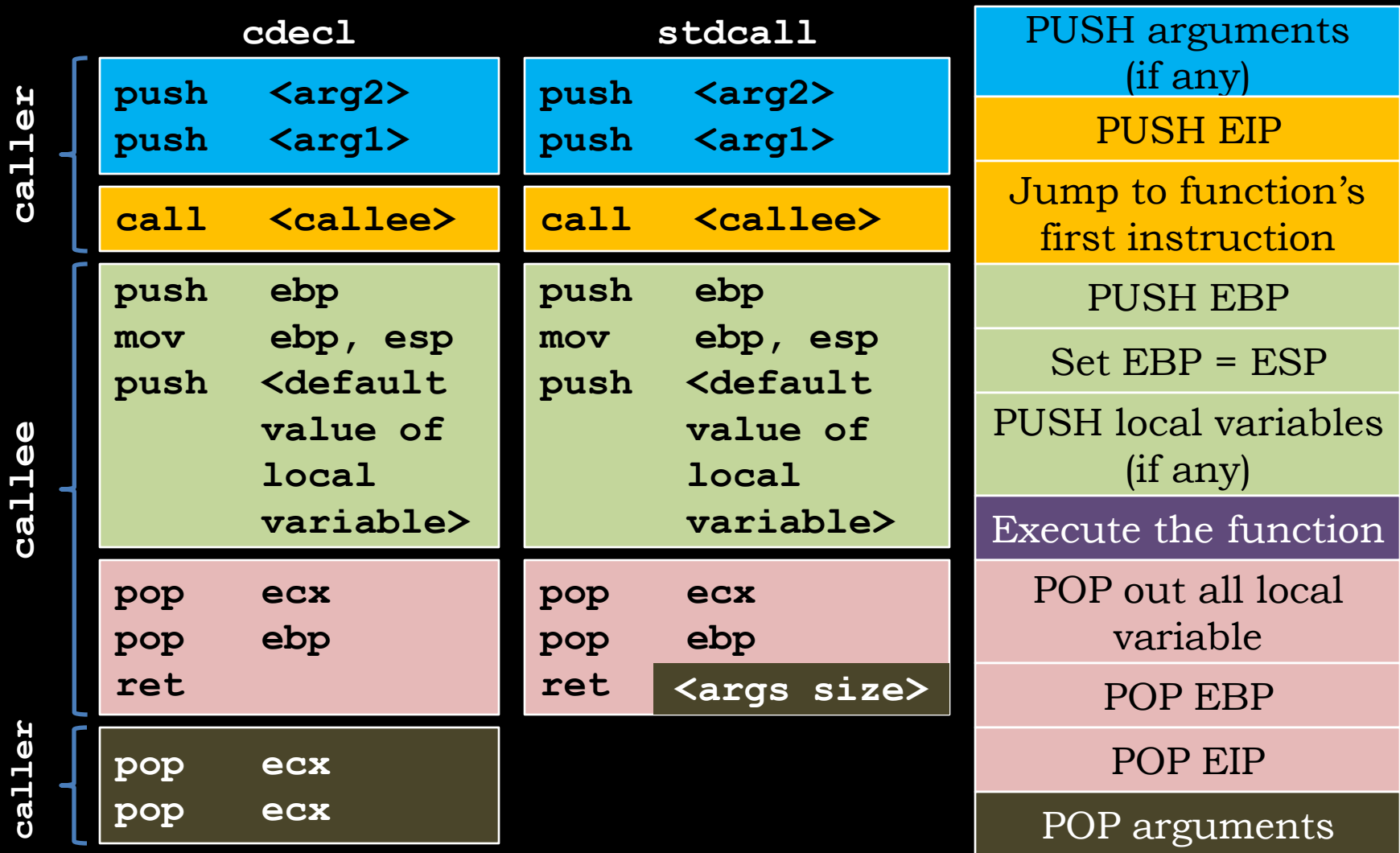

Functions, Low Level View

- General Trace -

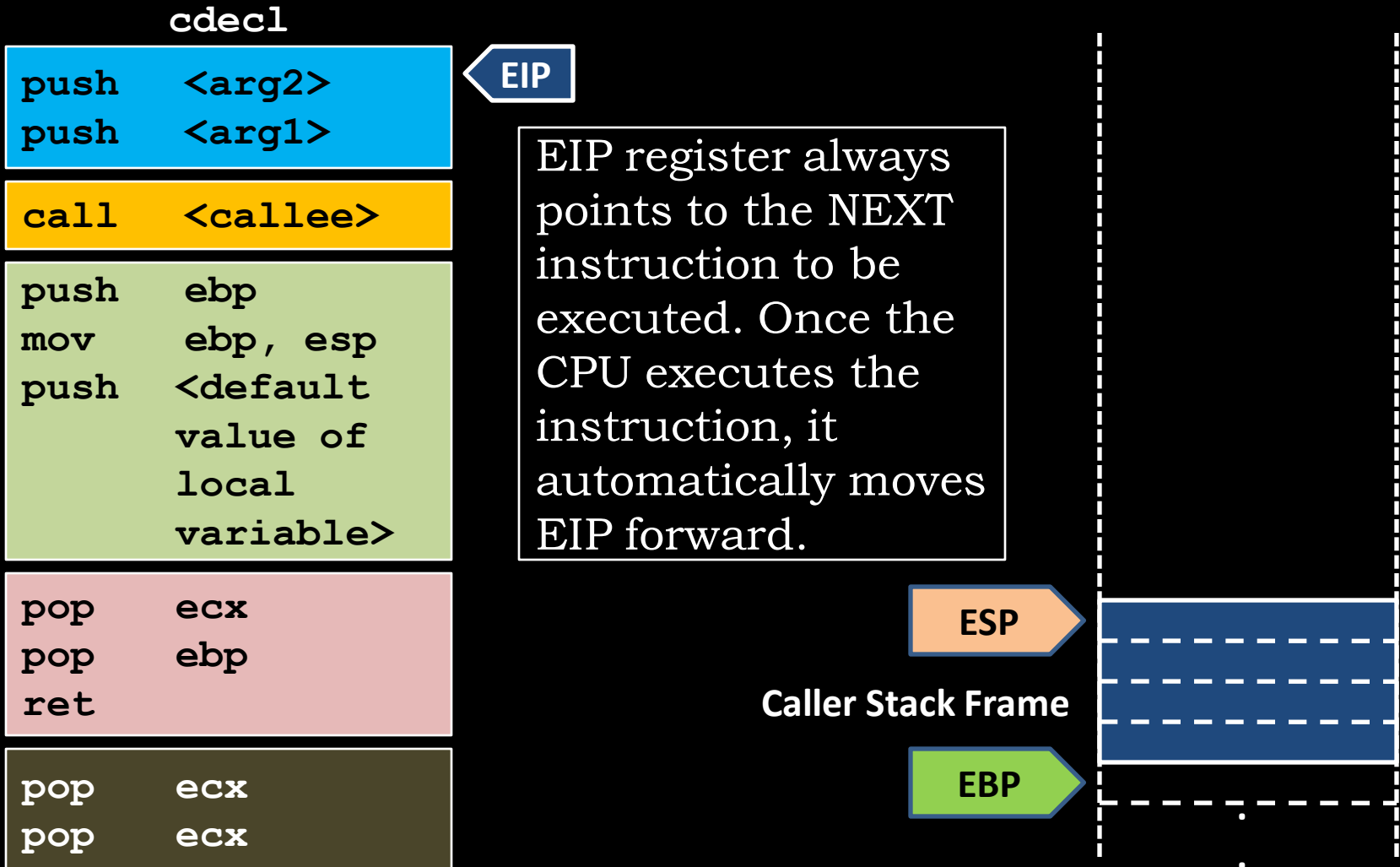

Functions, Low Level View

- General Trace -

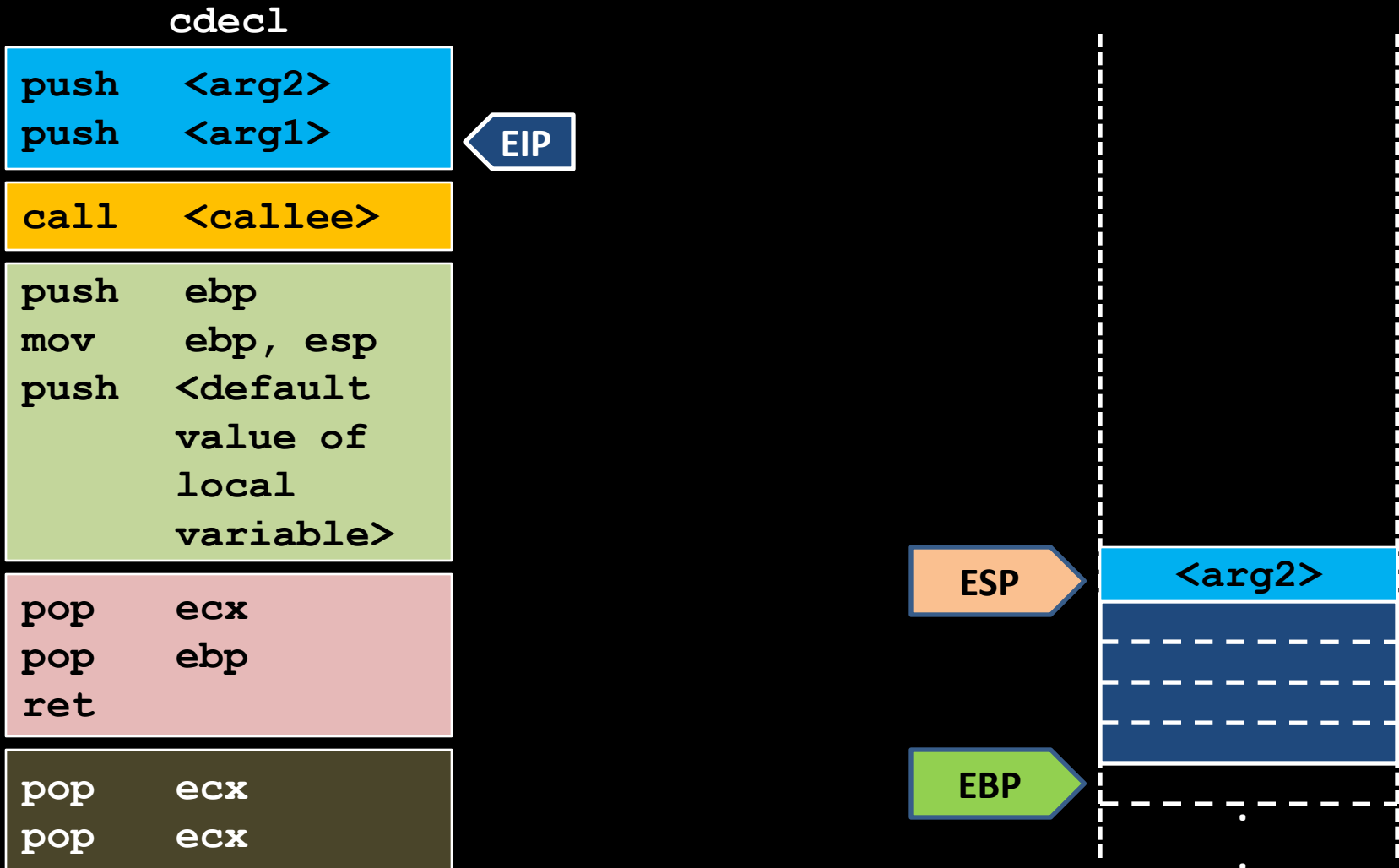

Functions, Low Level View

- General Trace -

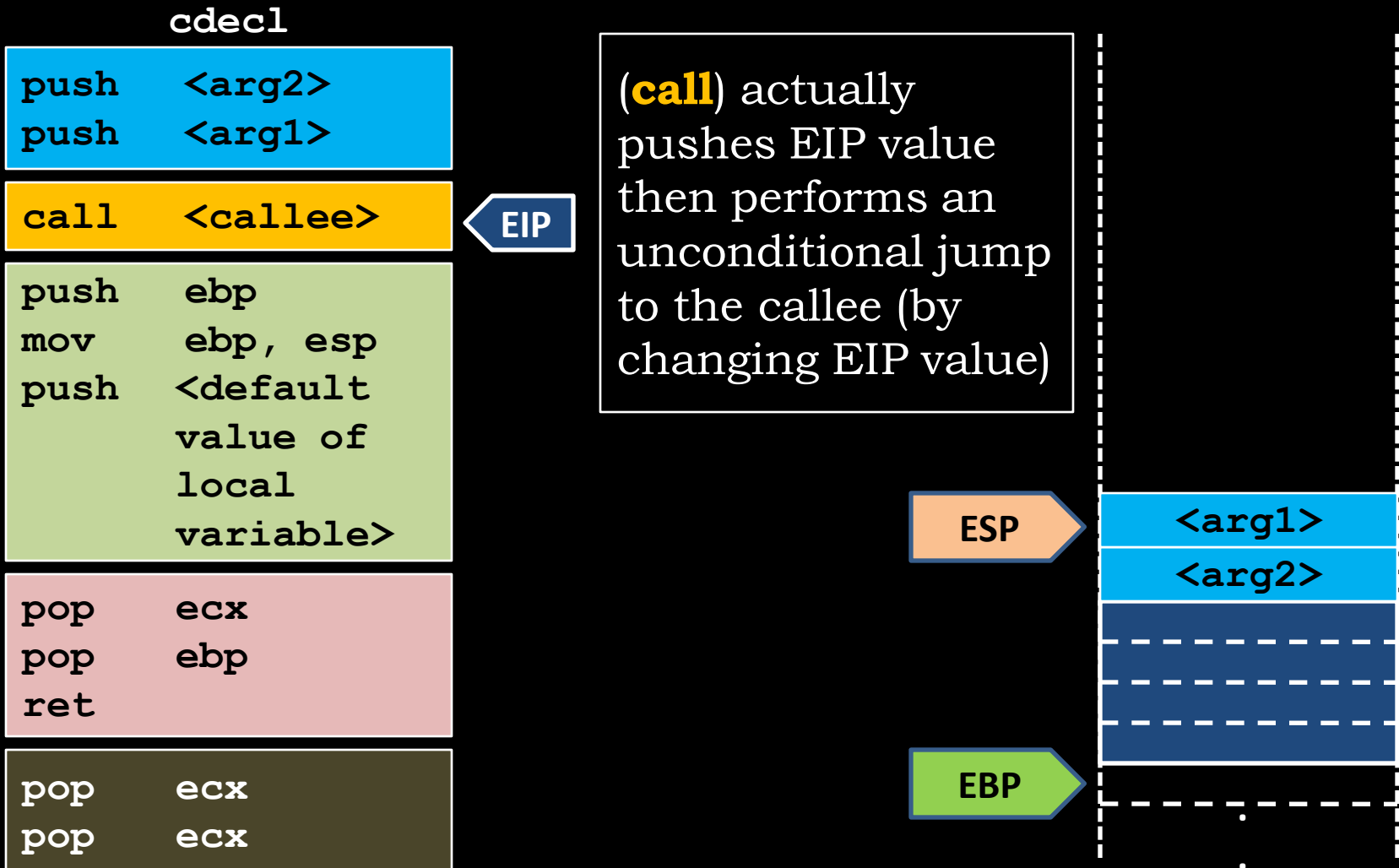

Functions, Low Level View

- General Trace -

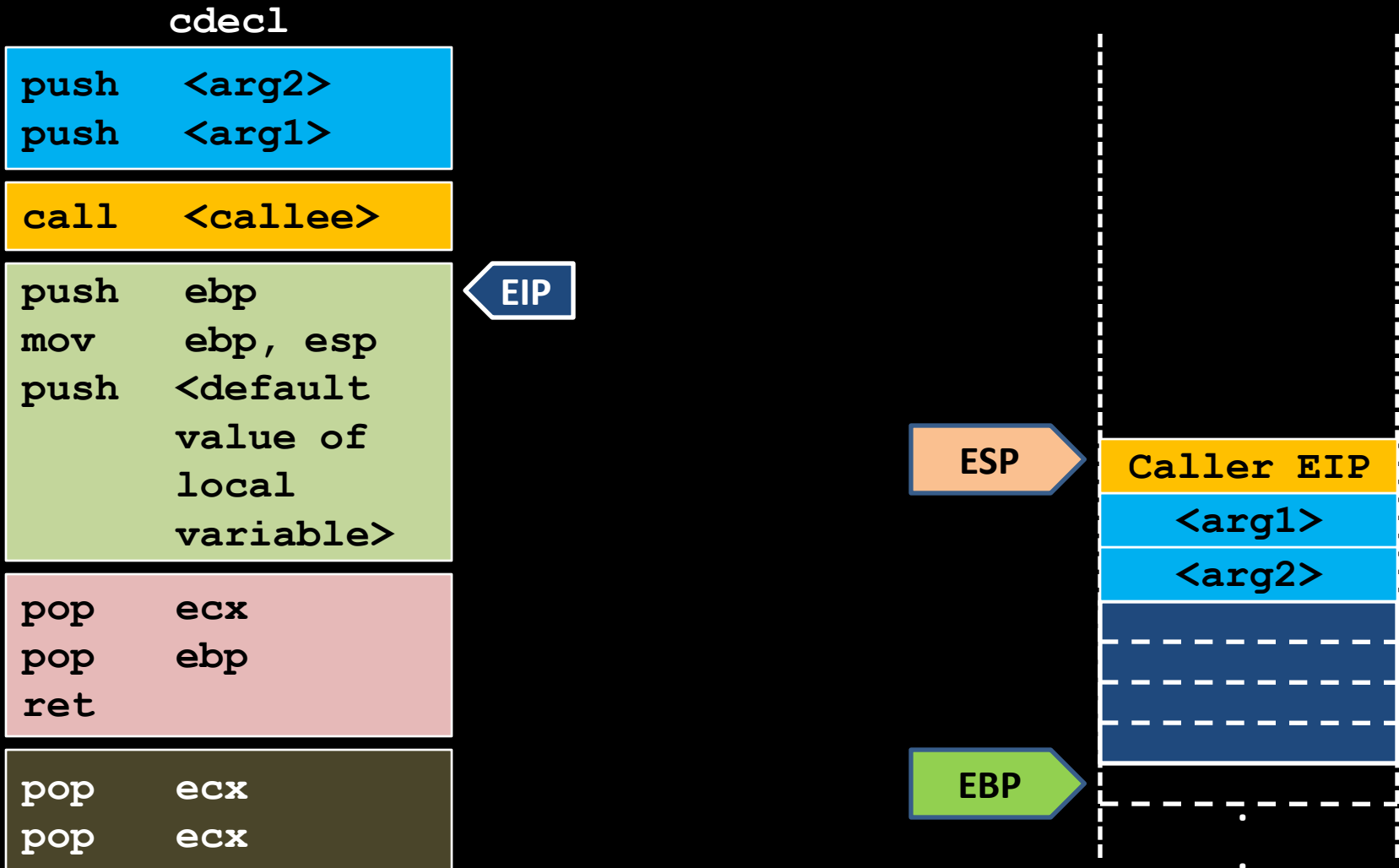

Functions, Low Level View

- General Trace -

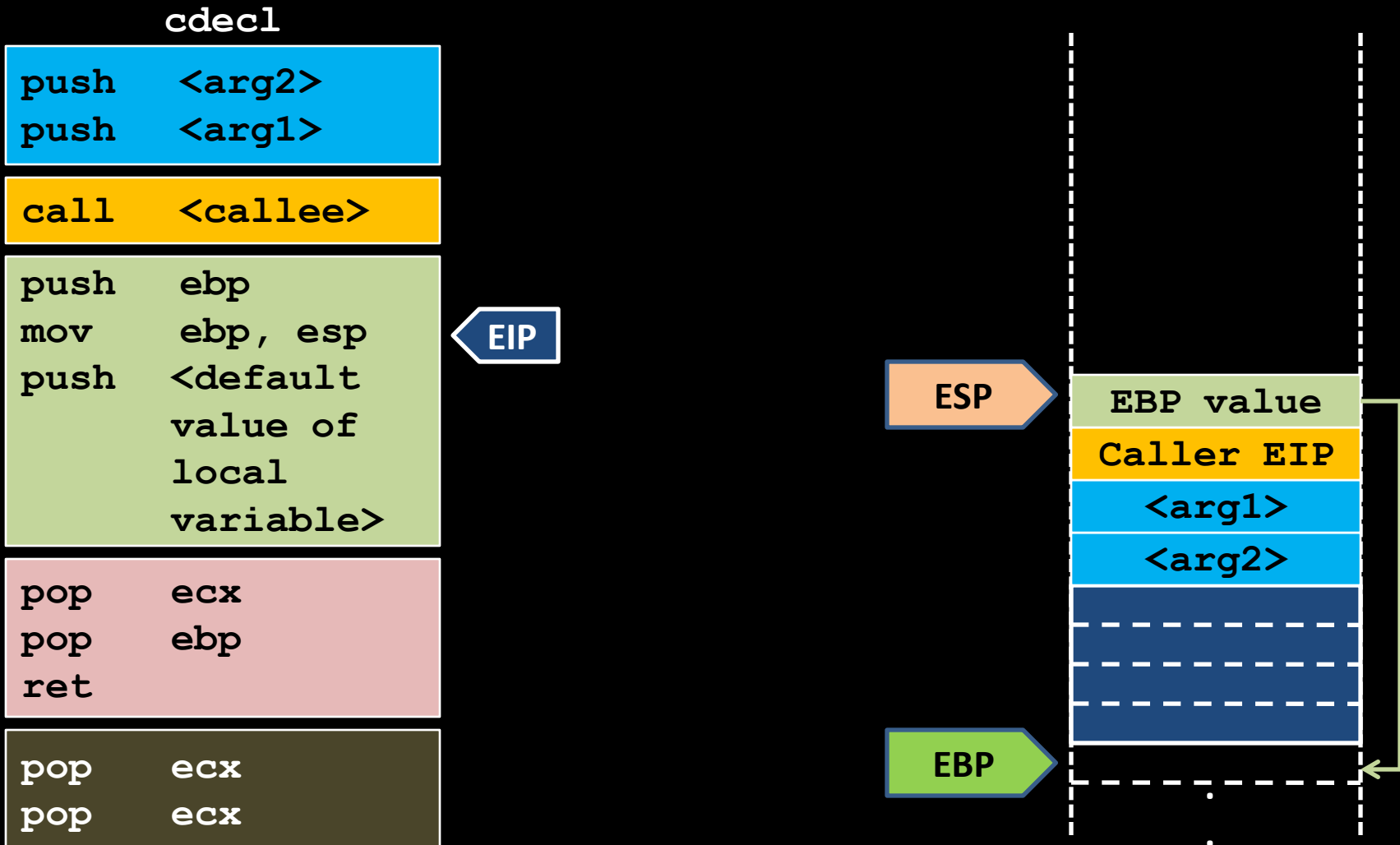

Functions, Low Level View

- General Trace -

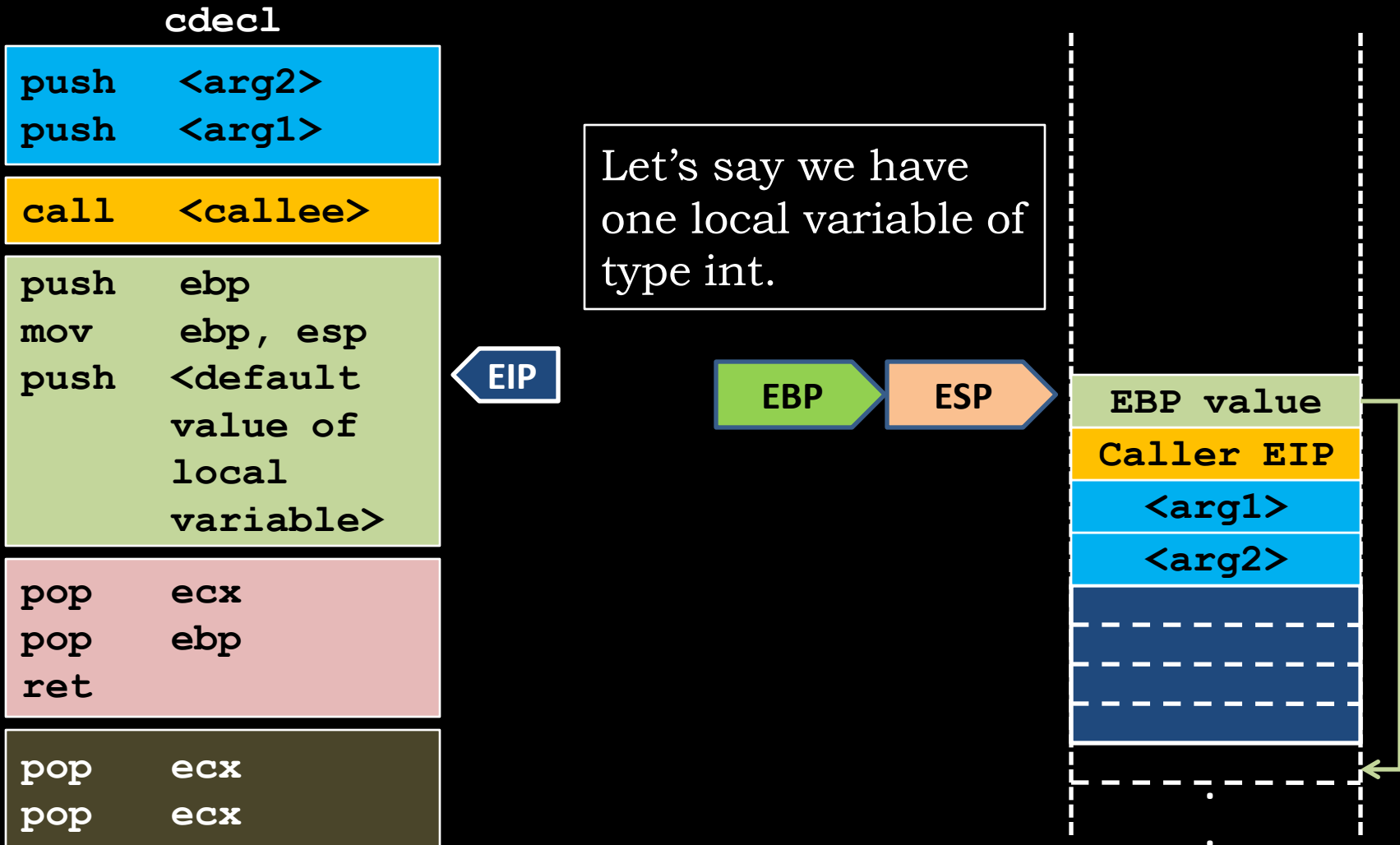

Functions, Low Level View

- General Trace -

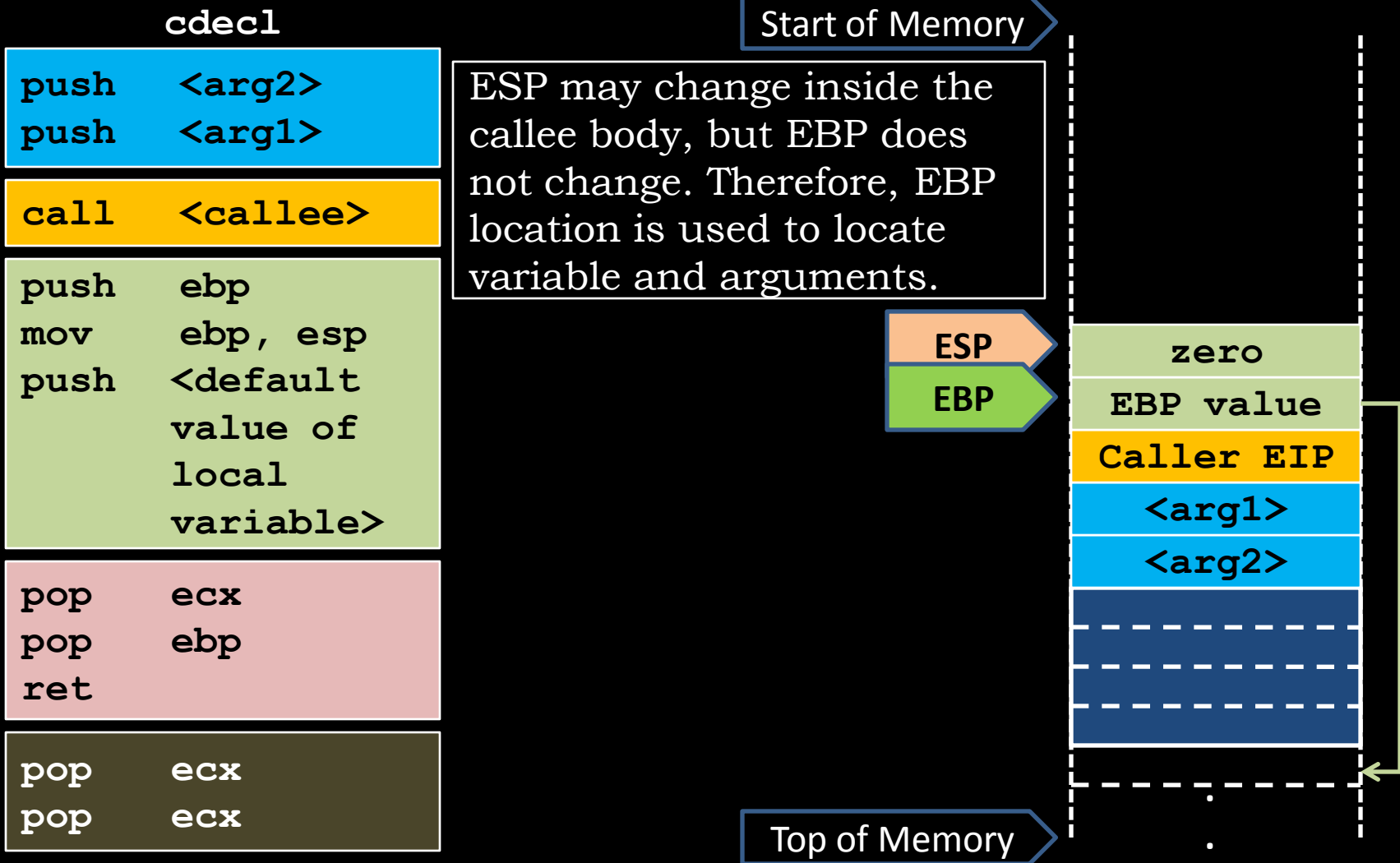

Functions, Low Level View

- General Trace -

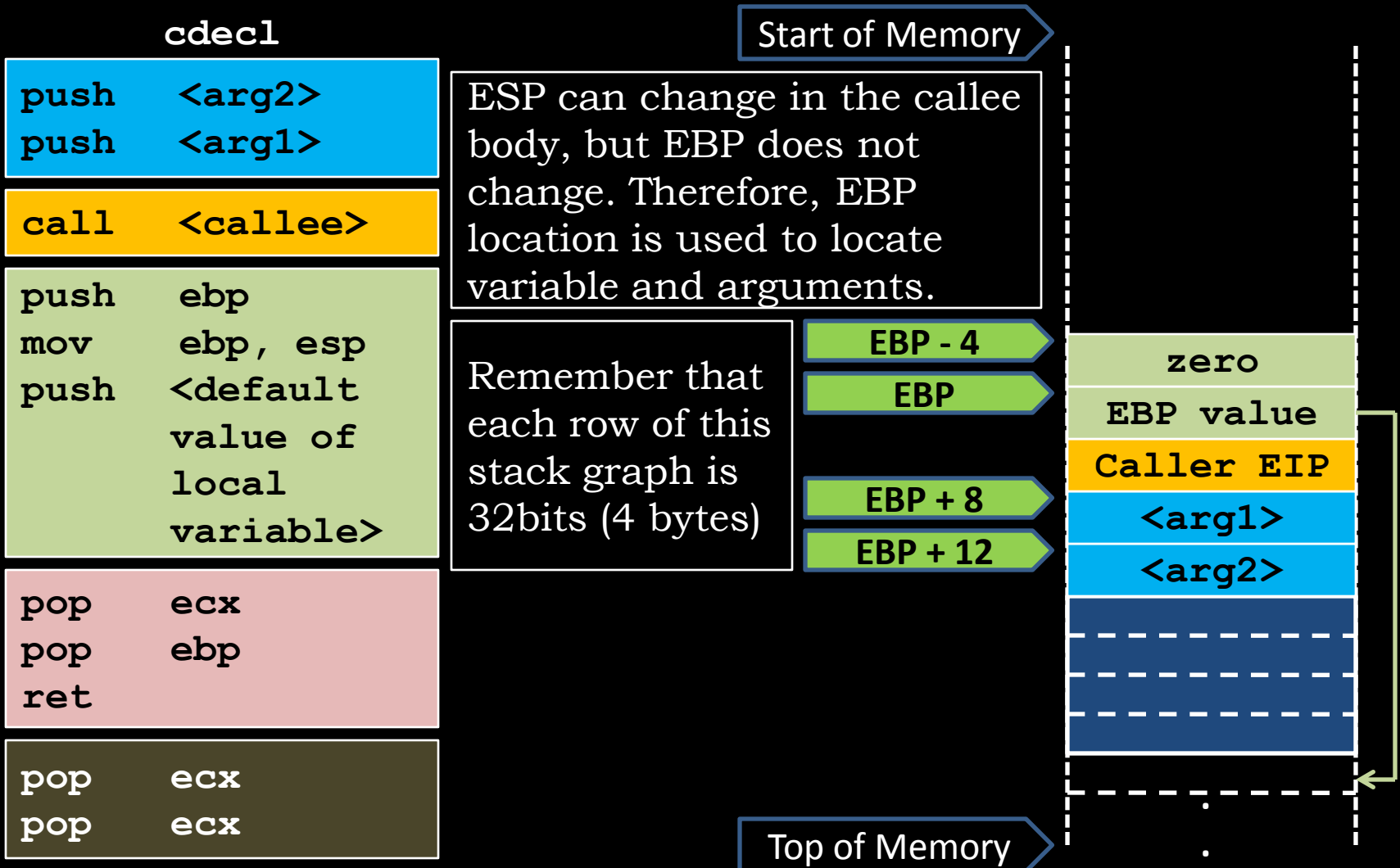

Functions, Low Level View

- General Trace -

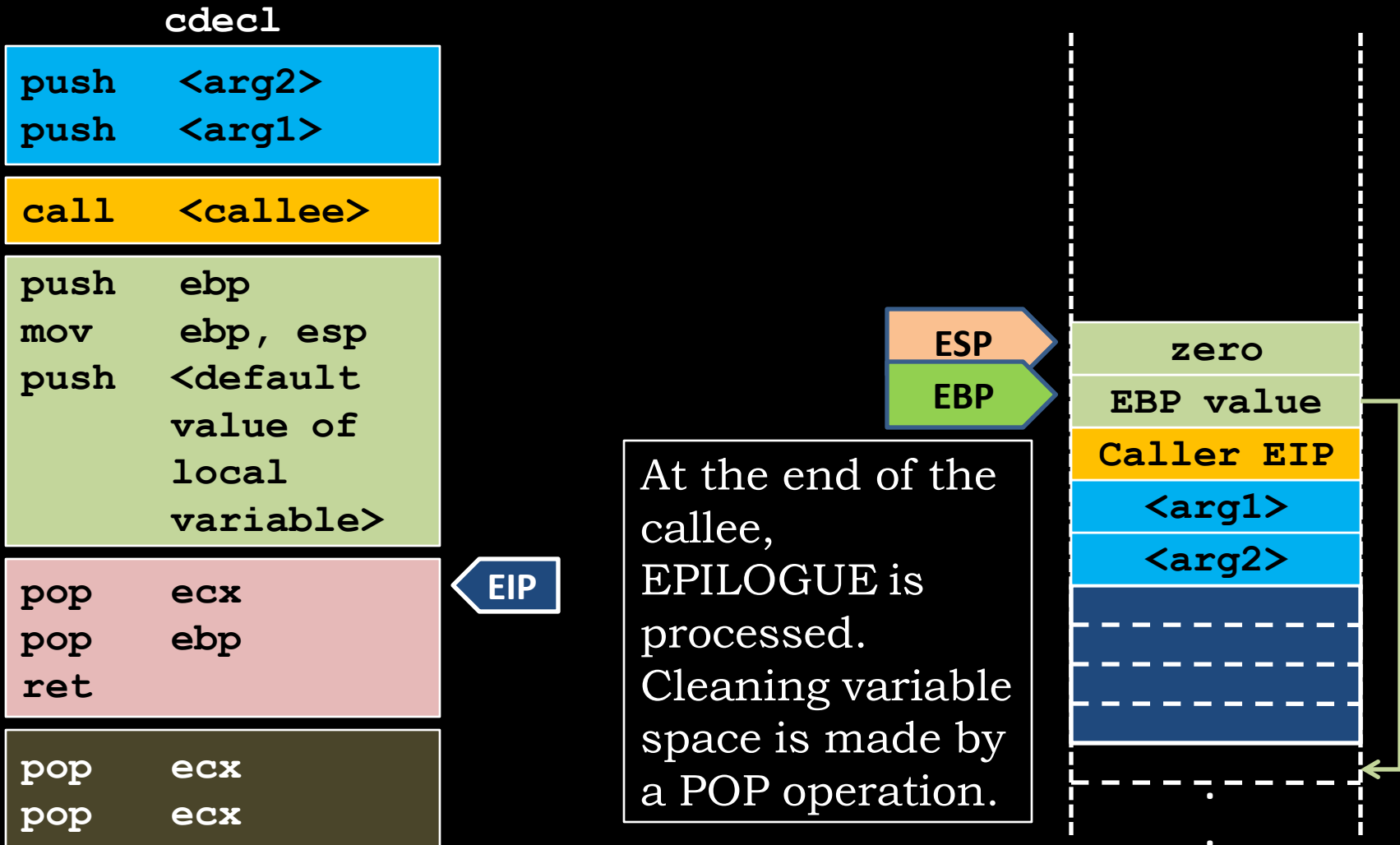

Functions, Low Level View

- General Trace -

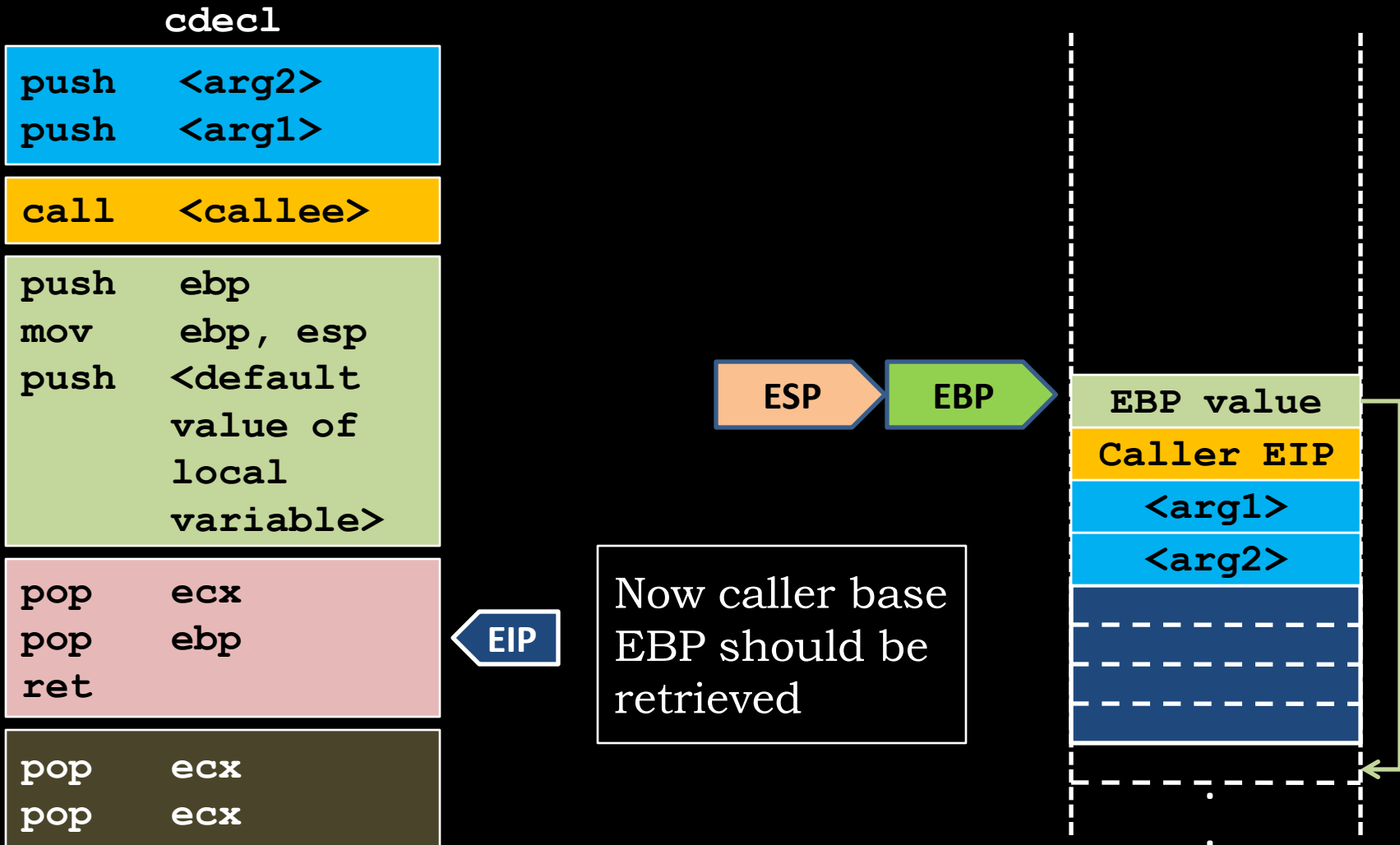

Functions, Low Level View

- General Trace -

`cdecl`

```
push <arg2>
push <arg1>
```

```
call <callee>
```

```
push ebp
mov  ebp, esp
push <default
value of
local
variable>
```

```
pop  ecx
pop  ebp
ret
```

```
pop  ecx
pop  ecx
```

Here comes the deference between `cdecl` and `stdcall`

`ret` instruction simply pops a value from the stack and save it in EIP, that should direct the execution back to the caller

EIP

ESP

EBP

Caller EIP

<arg1>

<arg2>

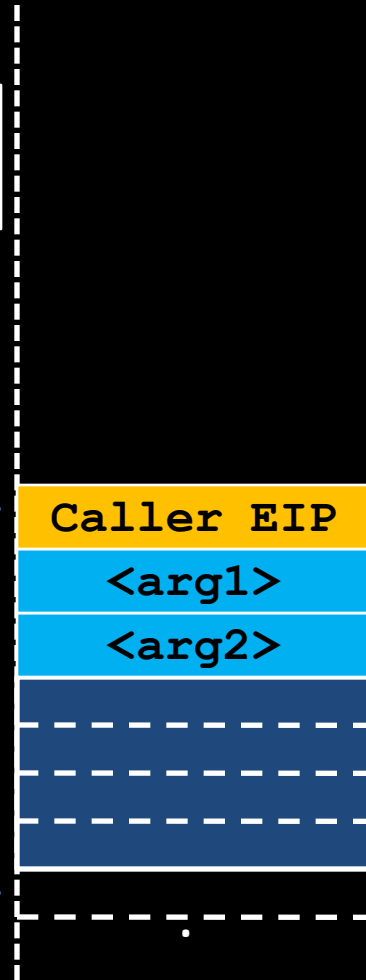

Functions, Low Level View

- General Trace -

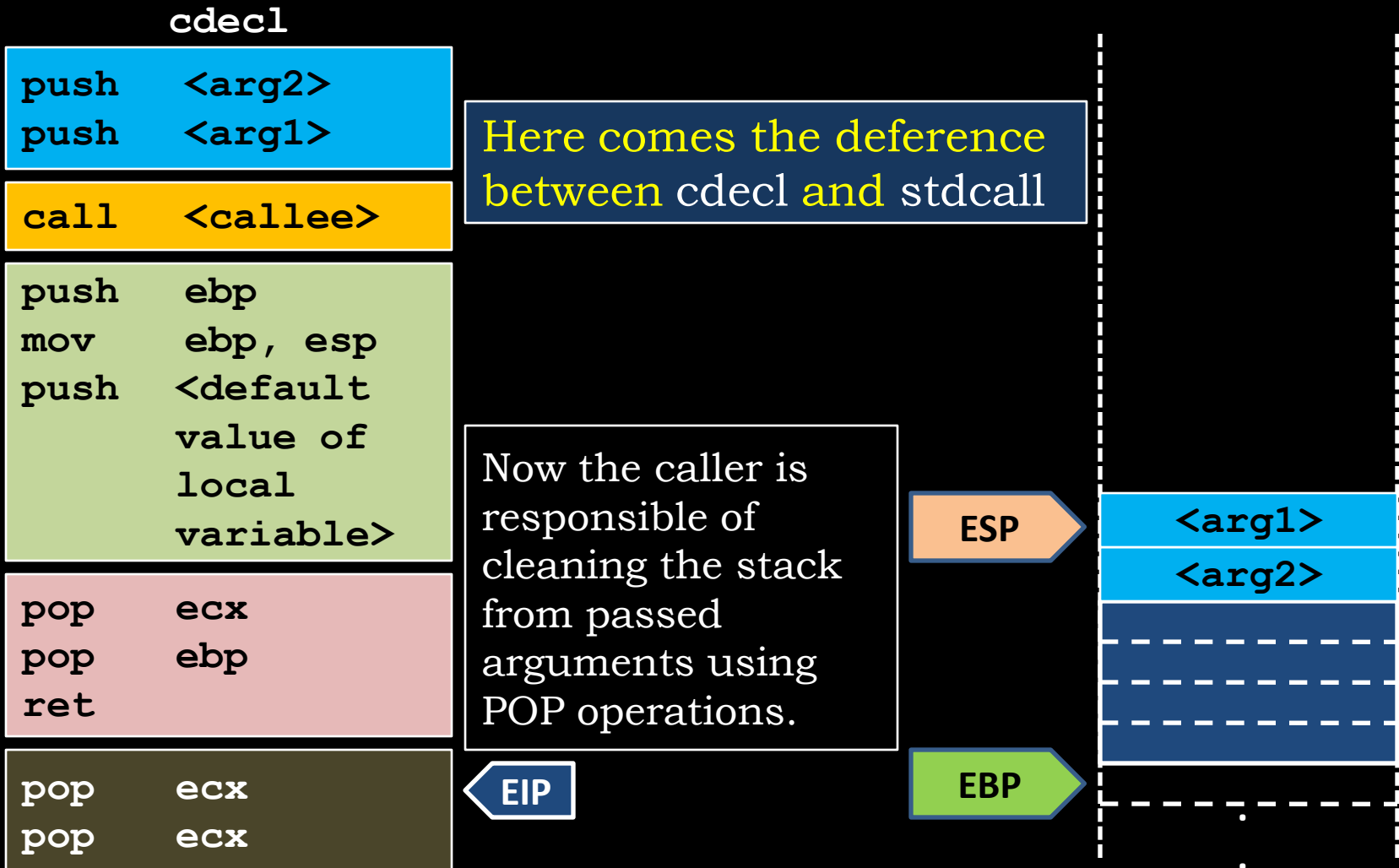

Functions, Low Level View

- General Trace -

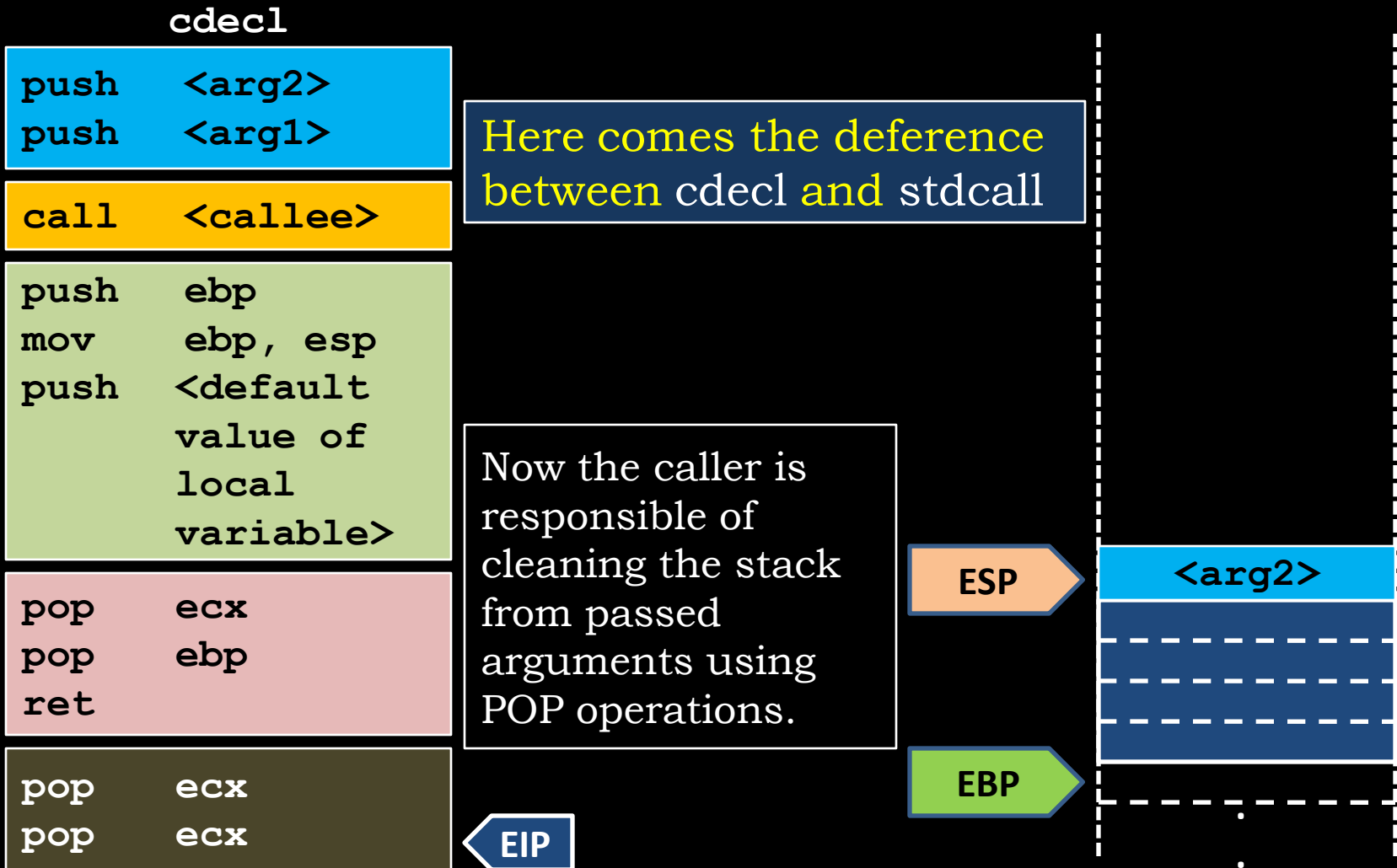

Functions, Low Level View

- General Trace -

`cdecl`

```
push <arg2>
```

```
push <arg1>
```

```
call <callee>
```

```
push ebp
```

```
mov ebp, esp
```

```
push <default  
value of  
local  
variable>
```

```
pop ecx
```

```
pop ebp
```

```
ret
```

```
pop ecx
```

```
pop ecx
```

Here comes the deference
between cdecl and stdcall

ESP

EBP

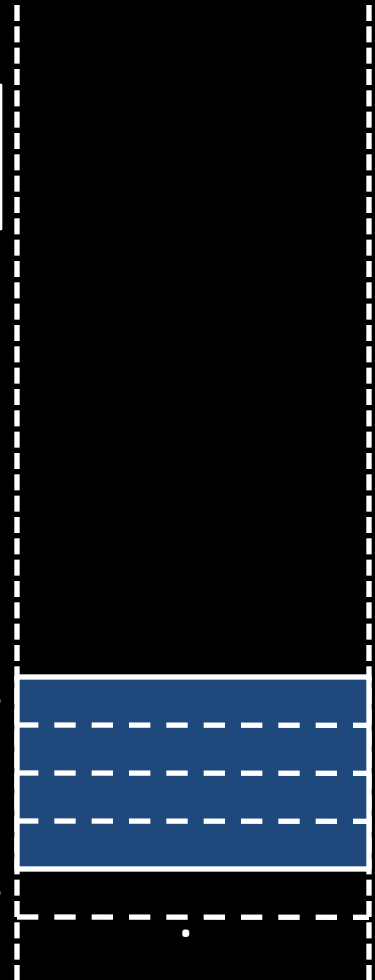

Functions, Low Level View

- General Trace -

stdcall

```
push <arg2>
push <arg1>
```

```
call <callee>
```

```
push ebp
mov  ebp, esp
push <default
value of
local
variable>
```

```
pop  ecx
pop  ebp
ret  <args size>
```

Here comes the deference
between cdecl and stdcall

ret instruction
preceded by an
integer value will
add that value to
ESP immediately
after performing
POP EIP

EIP

ESP

EBP

Caller EIP

<arg1>

<arg2>

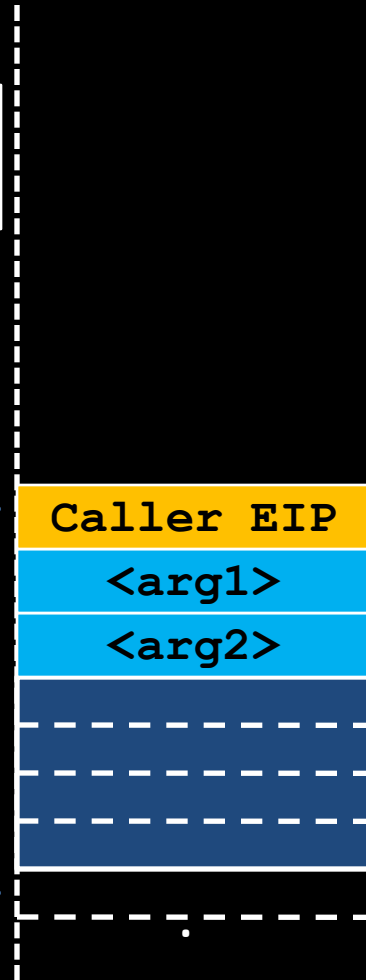

Functions, Low Level View

- General Trace -

stdcall

```
push <arg2>
push <arg1>
```

```
call <callee>
```

```
push ebp
mov  ebp, esp
push <default
value of
local
variable>
```

```
pop  ecx
pop  ebp
ret  <args size>
```

Here comes the deference
between cdecl and stdcall

Now EIP is changed, but the CPU did not finish executing the instruction. It will add <args size> value to ESP. In this example, we have two 32bits arguments (8 bytes)

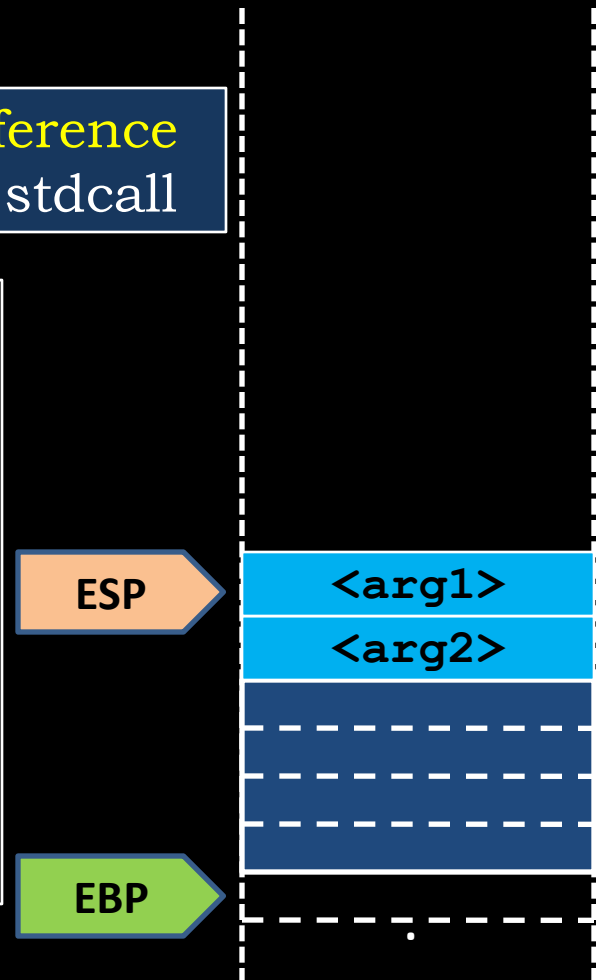

Functions, Low Level View

- General Trace -

stdcall

```
push <arg2>
push <arg1>
```

```
call <callee>
```

```
push ebp
mov  ebp, esp
push <default
value of
local
variable>
```

```
pop  ecx
pop  ebp
ret  <args size>
```

Here comes the deference
between cdecl and stdcall

The stack has been
cleaned by the
callee. Now
execution is back to
the caller.

ESP

EBP

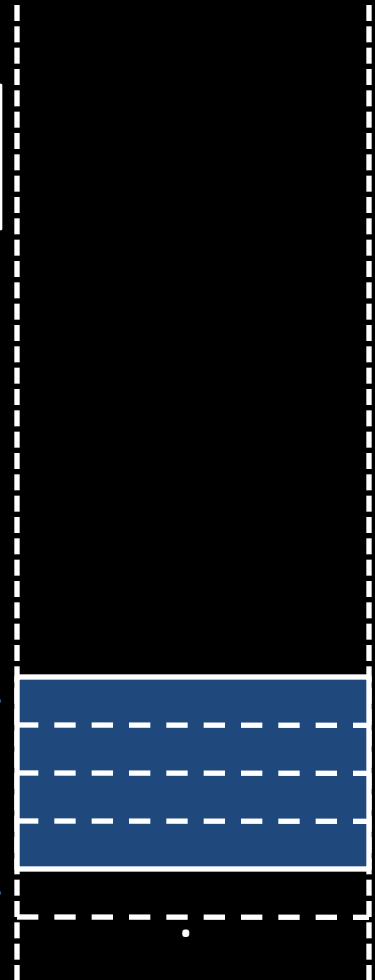

Functions, Low Level View

- Code Optimization -

- Compilers do not generate the default code like previous example. They use intelligent methods to optimize the code to be smaller and faster.
- For example, instructions `mov` and `xor` can be used to set EAX register to zero, but `xor` is smaller as a code byte. Therefore, compilers use `xor` instead of `mov` for such scenarios:
 - `mov eax, 0` → code bytes: `B8 00 00 00 00`
 - `xor eax, eax` → code bytes: `3C 00`
- Discussing code optimization is out of the scope of this course, but we are going to discuss few tricks that you will see in the code generated by GCC for our examples.

Functions, Low Level View

- Code Optimization -

`cdecl`

```
push  ebp
mov   ebp, esp
push  <default
      value of
      local
      variable>
```

```
pop   ecx
pop   ebp
ret
```

EIP

These instructions are going to be executed by the **callee**. Let's assume that **callee** is going to make another call to a function **foo** that require 1 integer argument. **callee** will set it's local integer variable to **7** then send double it's value to **foo**

EBP

ESP

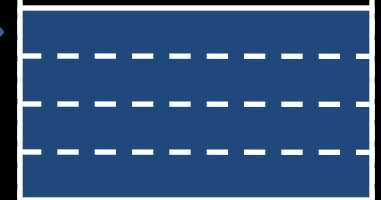

Functions, Low Level View

- Code Optimization -

cdecl

```
push ebp
mov  ebp, esp
push 0
```

```
mov  [ebp-4], 7
mov  ecx, [ebp-4]
add  ecx, ecx
```

```
push ecx
```

```
call <foo>
```

```
pop  ecx
```

```
pop  ecx
pop  ebp
ret
```

```
void callee(int arg1) {
    int v1;
    v1 = 7;
    foo(v1*2);
};
```

EIP

ESP

EBP - 4

EBP

14

7

Before we continue;
let's take a look on
the stack memory

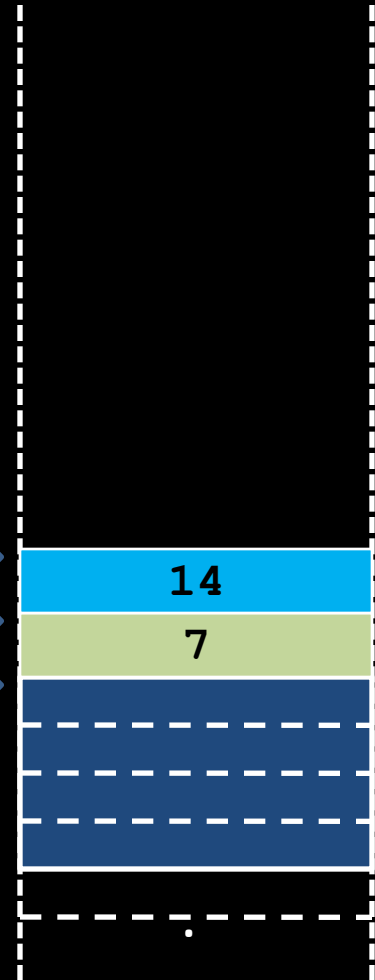

Functions, Low Level View

- Hint about Endianness -

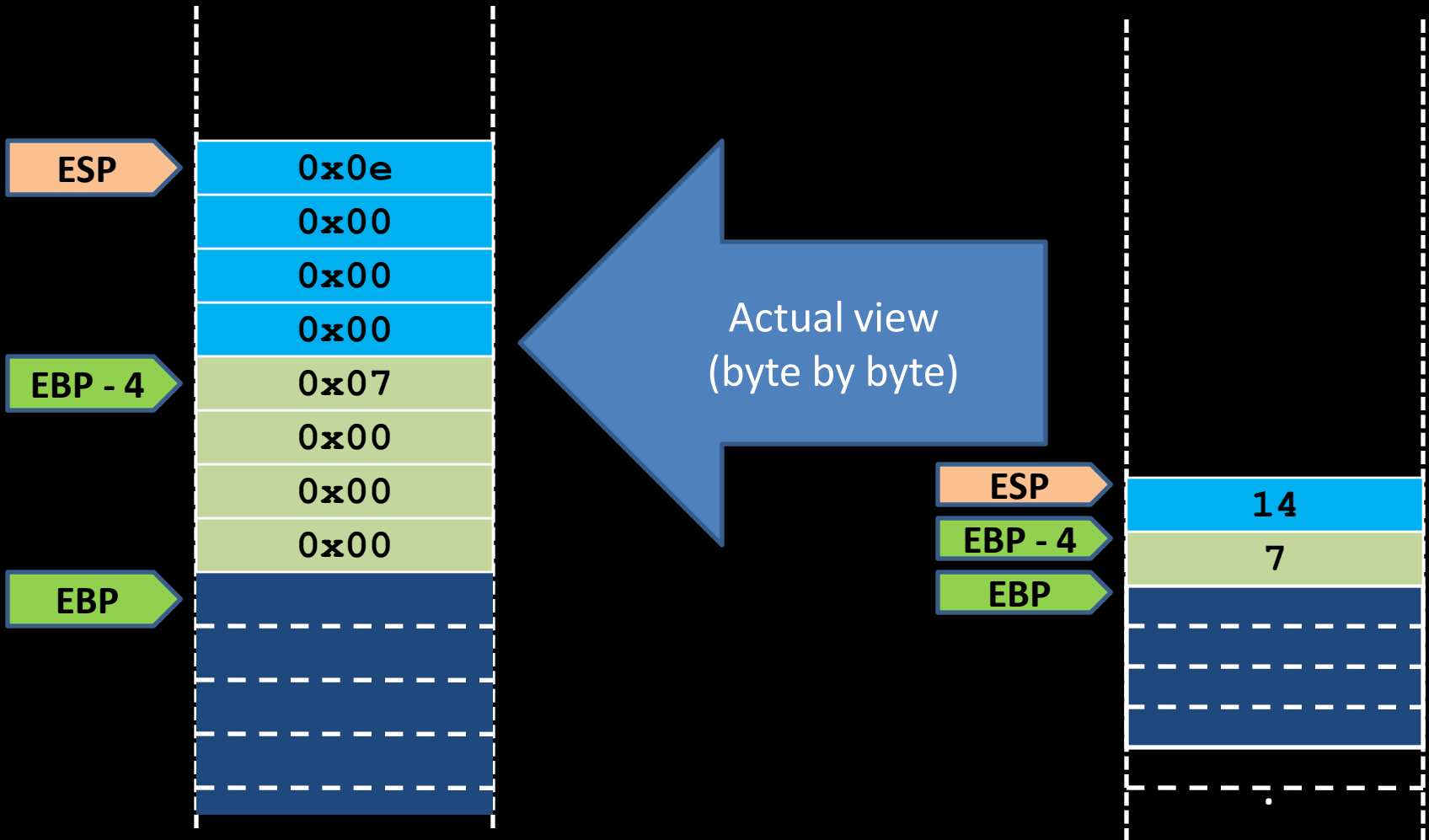

Functions, Low Level View

- Hint about Endianness -

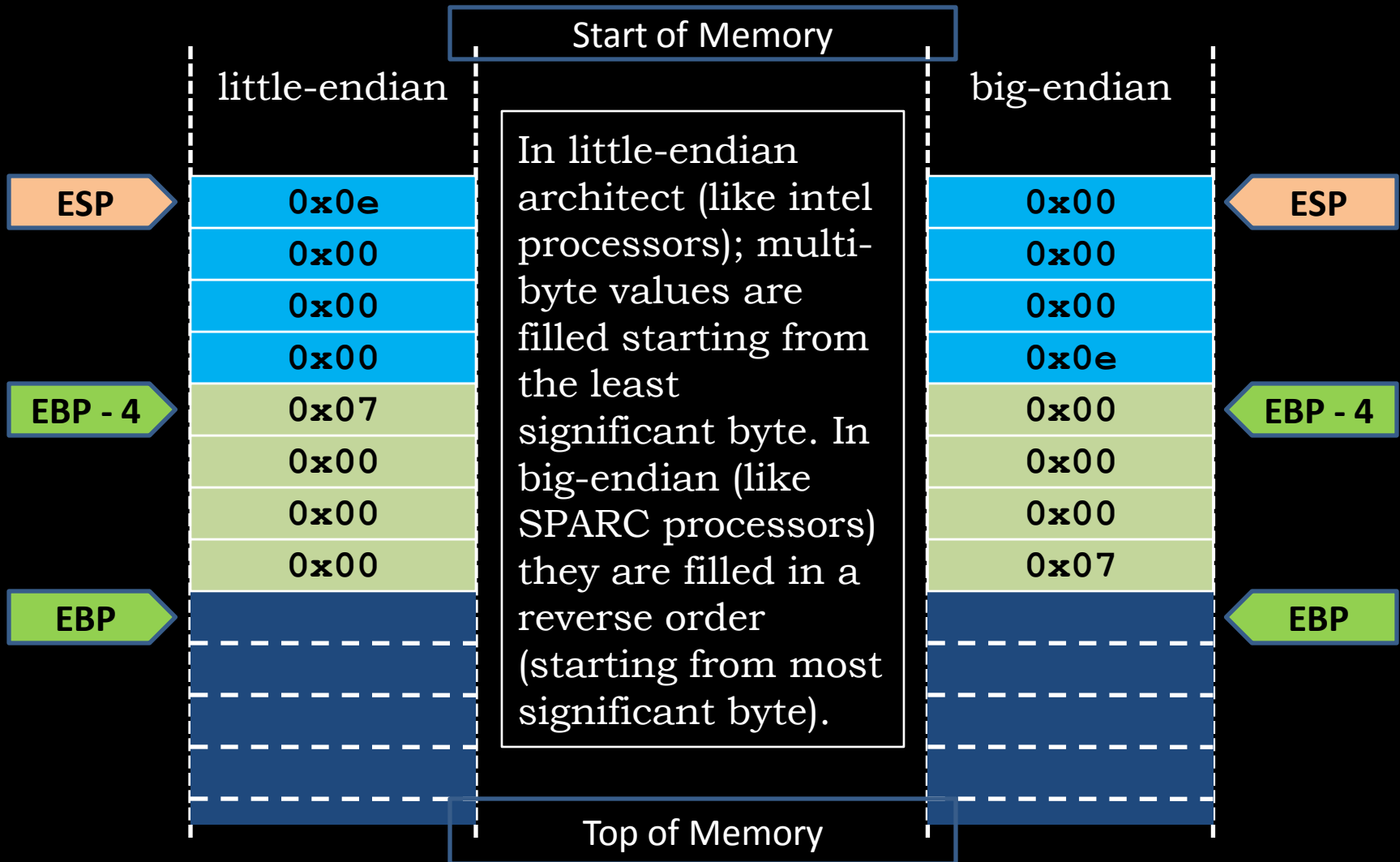

Functions, Low Level View

- Code Optimization -

cdecl

```
push ebp
mov  ebp, esp
push 0
```

```
mov  [ebp-4], 7
mov  ecx, [ebp-4]
add  ecx, ecx
```

```
push ecx
```

```
call <foo>
```

```
pop  ecx
```

```
pop  ecx
pop  ebp
ret
```

We can see that the default value **0** that was pushed in the epilogue section was not used. Compilers (like in C) do not push a default value. Instead; they reserve the space by moving ESP register

EIP

ESP

EBP - 4

EBP

14

7

Also, instead of performing POP to clean local variables space; we can move ESP to empty the stack frame

Functions, Low Level View

- Code Optimization -

cdecl

```
push ebp
mov  ebp, esp
sub  esp, 4
```

```
mov  [ebp-4], 7
mov  ecx, [ebp-4]
add  ecx, ecx
```

```
push ecx
```

```
call <foo>
```

```
pop  ecx
```

```
mov  esp, ebp
pop  ebp
ret
```

ESP will move to reserve space for the local variable, but that space is still not initialized.

Now you know exactly why uninitialized variables in C will contain unknown values (rubbish) ;)

EIP

ESP

EBP - 4

EBP

Another thing we can do is using the instruction **leave** which do exactly like these two instructions

14

7

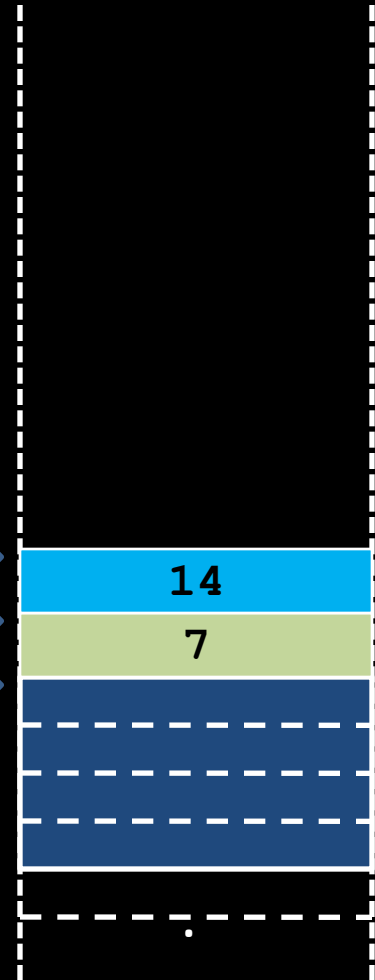

Functions, Low Level View

- Code Optimization -

`cdecl`

```
push ebp
mov  ebp, esp
sub  esp, 4
```

```
mov  [ebp-4], 7
mov  ecx, [ebp-4]
add  ecx, ecx
```

```
push ecx
```

```
call <foo>
```

```
pop  ecx
```

```
leave
ret
```

Compilers read the code in many passes before generating object-codes. One of the things the compiler does is calculating needed space for all arguments of called functions. In our example, `foo` needs 4 bytes.

EIP

ESP

EBP - 4

EBP

14

7

`push` is a slow instruction. Therefore, the compiler reserves the arguments space in the epilogue section

Functions, Low Level View

- Code Optimization -

cdecl

```
push ebp
mov  ebp, esp
sub  esp, 8
```

```
mov  [ebp-4], 7
mov  ecx, [ebp-4]
add  ecx, ecx
```

```
mov  [ebp-8], ecx
```

```
call <foo>
```

```
leave
ret
```

If `foo` takes two arguments, then `EBP-8` is the first one, and `EBP-12` is the second. (same as performing `push` for 2nd then 1st argument)

EIP

ESP

EBP - 4

EBP

14

7

`[ebp-8]` is for sure the argument to passed. But we can replace it with `[esp]` in this scenario only. (Why?)

Functions, Low Level View

- Code Optimization -

cdecl

```
push ebp
mov  ebp, esp
sub  esp, 8
```

```
mov  [ebp-4], 7
mov  ecx, [ebp-4]
add  ecx, ecx
```

```
mov  [esp], ecx
```

```
call <foo>
```

```
leave
ret
```



cdecl

```
push ebp
mov  ebp, esp
push 0
```

```
mov  [ebp-4], 7
mov  ecx, [ebp-4]
add  ecx, ecx
```

```
push ecx
```

```
call <foo>
```

```
pop  ecx
```

```
pop  ecx
pop  ebp
ret
```

Functions, Low Level View

- Example from GCC -

```
void myfun1(char *str) {
push    ebp
mov     ebp,esp
char buffer[16];
sub     esp, 0x18
strcpy(buffer, str);
mov     eax,DWORD PTR [ebp+8]
mov     DWORD PTR [esp+4],eax
lea    eax,[ebp-16]
mov     DWORD PTR [esp],eax
call   0x80482c4 <strcpy@plt>
myfun2(buffer);
lea    eax,[ebp-16]
mov     DWORD PTR [esp],eax
call   0x80483b4 <myfun2>
}
leave
ret
```

The function myfun1 require 16 bytes for the local array.

strcpy require 8 bytes for it's arguments

myfun2 require 4 bytes for it's arguments

The compiler made a reservation for 24 bytes (0x18) which is 16 for array + 8 for **maximum** arguments space

Functions, Low Level View

- Example from GCC -

```
void myfun1(char *str) {
push    ebp
mov     ebp,esp
char buffer[16];
sub     esp,0x18
strcpy(buffer, str);
mov     eax,DWORD PTR [ebp+8]
mov     DWORD PTR [esp+4],eax
lea    eax,[ebp-16]
mov     DWORD PTR [esp],eax
call   0x80482c4 <strcpy@plt>
myfun2(buffer);
lea    eax,[ebp-16]
mov     DWORD PTR [esp],eax
call   0x80483b4 <myfun2>
}
leave
ret
```

By default, EBP+4 points to the saved EIP of the caller (`main` in this example). EBP points to the saved EBP by epilogue section.

strcpy takes two arguments, destination `dst` then source `src`.

EBP+8 is the sent value by the caller `main` to the callee `myfun1` that is named `str` in this code.

EIP

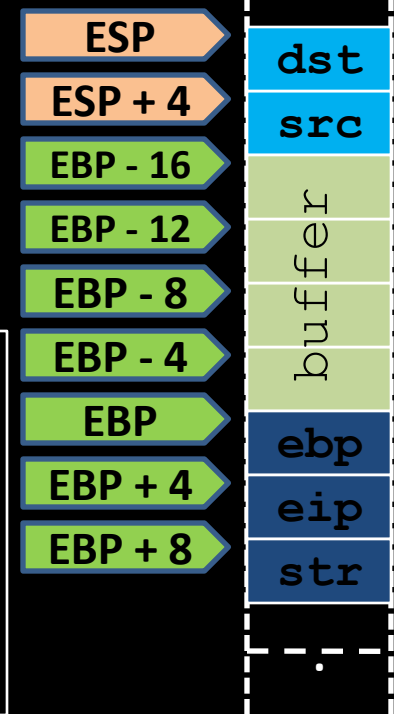

Functions, Low Level View

- Example from GCC -

```
void myfun1(char *str) {
push    ebp
mov     ebp,esp
char buffer[16];
sub     esp,0x18
strcpy(buffer, str);
mov     eax,DWORD PTR [ebp+8]
mov     DWORD PTR [esp+4],eax
lea     eax,[ebp-16]
mov     DWORD PTR [esp],eax
call   0x80482c4 <strcpy@plt>
myfun2(buffer);
lea     eax,[ebp-16]
mov     DWORD PTR [esp],eax
call   0x80483b4 <myfun2>
}
leave
ret
```

EIP

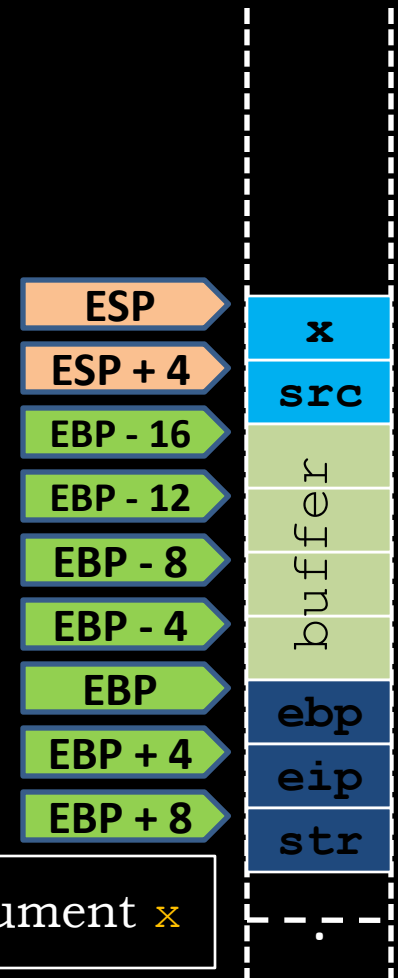

myfun2 takes one argument x

Functions, Low Level View

- Example from GCC -

```
void myfun2(char *x) {
push    ebp
mov     ebp,esp
sub     esp,0x8
printf(" You entered: %s\n", x);
mov     eax,DWORD PTR [ebp+8]
mov     DWORD PTR [esp+4],eax
mov     DWORD PTR [esp],0x8048520
call   0x80482d4 <printf@plt>
}
leave
ret
```

EIP

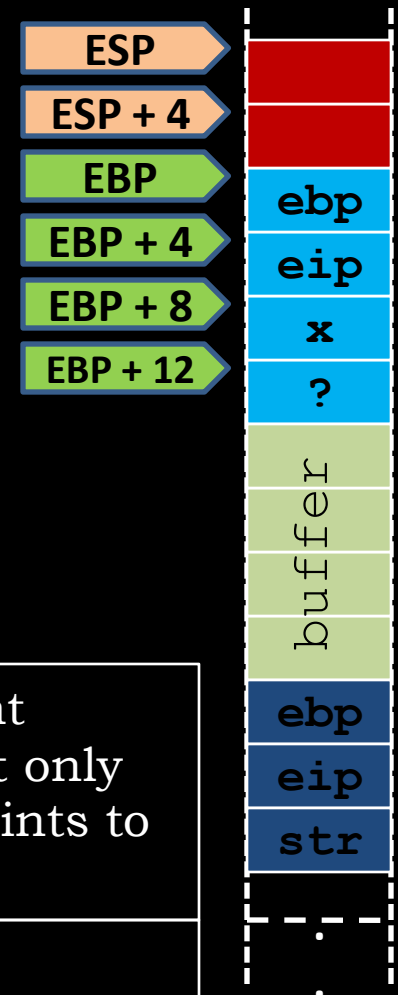

EBP+8 points to the first argument sent to the current function. EBP+12 points to the second and so on. But only one argument used by `myfun2`. Therefore, EBP+12 points to an irrelevant location as `myfun2` can see.

Can you guess what is currently saved in [EBP+12] ?

Functions, Low Level View

- Example from GCC -

```
int main(int argc, char *argv[]){
push    ebp
mov     ebp,esp
sub     esp,0x4
if (argc > 1)
cmp     DWORD PTR [ebp+8],0x1
jle     0x8048412
myfun1(argv[1]);
mov     eax,DWORD PTR [ebp+12]
add     eax,0x4
mov     eax,DWORD PTR [eax]
mov     DWORD PTR [esp],eax
call   0x80483cf <myfun1>
jmp     0x804841e
else printf("No arguments!\n");
mov     DWORD PTR [esp],0x8048540
call   0x80482d4 <printf@plt>
}
leave
ret
```

`main` is a function as like as any other function.

Can you tell what these instructions do?

EIP

ESP

EBP

EBP + 4

EBP + 8

EBP + 12

str

ebp

<m1>

<m2>

<m3>

What do these memory locations contain <m1>, <m2>, and <m3>?

Functions, Low Level View

- Stack Reliability -

So,

What if we can locate **Caller EIP** in the stack and change it using `mov` or any other instruction?

What if the new value is a location of another block of code?

What if the other block of code is harmful (security wise)?

Bad for the user, good for the Exploit ☺

Start of Memory

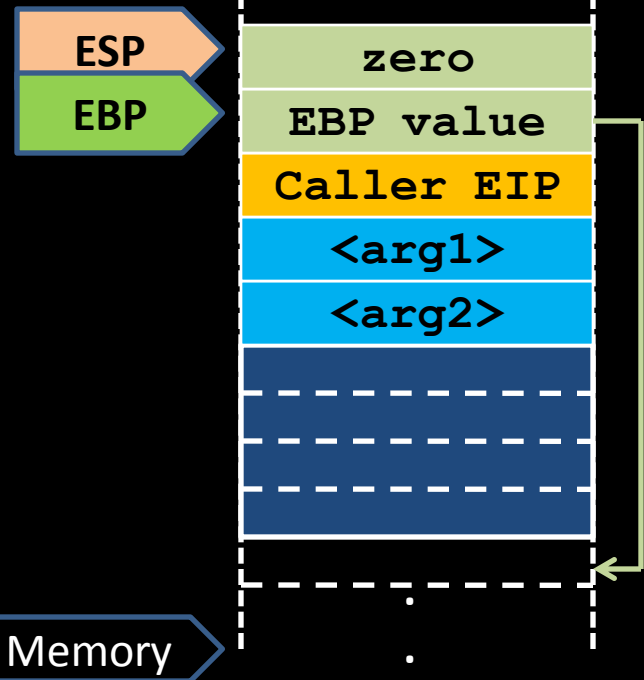

Top of Memory

References

All references found at
the end of part 3.